



ALUMTURK



GENEL SATIŞ KOŞULLARI

Profillerin Ağırlık ve boyutları

Bu katalogda belirtilen profillerin ağırlık ve boyutları teorik olup, boyut toleranslarına, kalınlık ve ekstrüzyonlara göre değişiklik gösterebilir. (UNI EN 12020-2).

Alüminyum Alaşım

Ekstrüzyon profiller EN AW 6060 T5(UNI EN 12020-2).

Boy Uzunluğu

Genel uzunluk 6500 mm.

Diğer ölçüler için lütfen iletişime geçin.

Kesme boyutları

Bu katalogda raporlanan kesim listeleri ve takım listeleri bulunmaktadır. Bildirilen ölçüler doğrudur ancak kendi atölyesindeki takımlara ve makinelere göre yuvarlama yapılması gereklidir.

İlk üretimleriniz için veya büyük miktarda bağlantı olması durumunda, bir miktar prova numunesi gerçekleştirmenizi öneririz.

Kesitler, bölümler, duvara sabitleme

Sabitlenme montajı sırasında bulabileceğiniz bazı genel durumları açıklamak için kesitler, kesitler ve duvara sabitleme bu katalogda belirtilmiştir.

Perde duvar boyutları

Giydirme cephe boyutlarını belirlemek için bazı unsurları göz önünde bulundurmak gerekir: profiller atalet momentleri, cam boyutları ve ağırlığı, açılır kanatların boyutları, aksesuarların kalitesi ve kapasitesi, duvara sabitleme türü ve sayısı, döşeme durumu (yükseklik, maruz kalma, rüzgar bölgesi, vb.).

Raporlanan diyagramlar, profillerin ön atalet momentlerine göre detaylandırılmıştır.

Bu katalogda bildirilen bilgiler gösterge niteliğindedir; Mkav Alüminyum, ürünü geliştirmek için gerekli gördüğü takdirde, bu katalogda yer alan herhangi bir öğeyi haber vermeksizin değiştirme hakkını saklı tutar.

Giydirme cephe imalatı sırasında Türkiye'de geçerli olan yönetmeliklere ve özel tavsiyelere uyulmasını öneriyoruz. Giydirme cephe imalatı için bu katalogda belirtilen teknolojiyi takip etmenizi öneririz; Bu katalogda tavsiye edilen conta ve aksesuarların kullanılmasını tavsiye ederiz.

Mkav Alüminyum'un sorumluluğu, orijinal olarak kusurlu çıkan ürünlerin değiştirilmesi ile sınırlıdır.

GENERAL SALES CONDITIONS

Weight and dimension of profiles

Profiles weight and dimensions reported on this catalogue are theoretic, they can vary according to dimensional tolerances, thickness and extrusions (UNI EN 12020-2).

Extrusion alloy

Extruded profiles EN AW 6060 T5 alloy (UNI EN 12020-2).

Bars length

Commercial bars length is 6500 mm.

For different dimensions ask to furnisher.

Cutting dimensions

In this catalogue are reported cutting lists and tooling lists. Reported dimensions are correct but is necessary consider rounding off according to the tooling up and machines of one's own workshop.

We suggest, for your first productions or in case of large quantity of fastenings, to execute some proof sampling.

Cross sections, sections, fixing to wall

Cross sections, sections and fixing to wall are reported on this catalogue to explain some common situations that you can find during fastening assembly.

Curtain wall dimensions

To determine curtain wall dimensions is necessary consider some elements: profiles inertia moments, dimensions and weight of glass, dimensions of opening wings, quality and capacity of accessories, type and number of fixing to wall, situation of laying (height, exposure, wind zone, etc.).

Diagrams reported were elaborate according to frontal inertia moments of profiles.

Informations reported in this catalogue are indicative; they don't commit Mkav Aluminum. Mkav Aluminum reserves the faculty to modify any item contained in this catalogue without notice, if it should deem it necessary in order to improve the product.

During curtain walls manufacture, we suggest to keep to regulations and specific recommendations, current in Italy. To manufacture curtain walls we suggest to follow technology reported on this catalogue; more-over we suggest to use gaskets and accessories recommended on this catalogue. Mkav Aluminum responsibility is limited to replacement of products coming out defective originally.

Index

GENEL BÖLÜMLER	
<i>Profil Listeleri</i> <i>List of Profiles</i>	pag. 05
<i>Aksesuar ve Contalar</i> <i>Accessories and Gaskets</i>	pag. 19
<i>Sertifikalar</i> <i>Certificates</i>	pag.133
Taşıma Yapısı Carrying Structure	pag. 31
Takımlar Toolings	pag. 37
Duvara Monteleme Fixing to Wall	pag. 59
Statik değerler Strenght Characteristics	pag. 77
Cephe Sistemleri Types of Facades	pag. 89
Kanat takımları Wing toolings	pag. 119

YAPI ÖZELLİKLERİ

UZAK DUVAR sisteminde çeşitli yarı yapısal, yapısal, camlı, normal veya termik kırma perde duvar tipolojileri vardır.

BAĞIMSIZ ÜNİTELERLE PERDE DUVARLAR

Ana yapı özellikleri, hem vernikli hem de anodize edilmiş EN AW 6060 alüminyum alaşımı T5 sertleştirilmiş ve temperlenmiş bir iç yük taşıyıcı ızgara ve bir dış panel veya cam yatak ünitesidir.

Dahili yük taşıyıcı ızgara

Özel bir sabitleme sistemi vasıtasıyla binaya sabitlenmiş bir dizi bağımsız taşıyıcı elemandan oluşur.

Taşıyıcı elemanlar uygun genişleme emici derzler araya getirilerek birbirine bağlanır ve masterlı civatalarla monte edilir.

Taşıyıcı elemanlar

Taşıyıcı eleman, birbirine bağlı dikmeler ve vasistaslardan oluşan ızgaradır. Dikmeler ve vasistaslar, kendinden dış açan vidalar (görünmez) ve yük taşıyan yapıya su ve hava sızdırmazlığını garanti eden termoplastik ara bağlantılarla birleştirilir.

Atalet momentlerine göre bir araya getirilen tirizler aşağıdaki boyutlardadır: 70x60 veya 70x112 ve yapının iç kısmına takviye profilleri eklenerek daha da güçlendirilebilir. Giydirme cephenin atalet momentlerine ve tirizler arası mesafeye göre iki tip vasistas vardır: 70x77 veya 70x129.

Genişleme emici eklemler

Alüminyum profillerin hem yatay hem de dikey eksenlerde lineer ısıl genişmesini absorbe etmek için gerekli olan, elemanlar arasındaki bağlantı bölgelerine yerleştirilen ara bağlantı elemanlarıdır. İki tür bağlantı elemanları vardır:

a) bitişik elemanlar arasında: bu, elemanların ortaları boyunca uzanan ve iki bitişik eleman arasında paylaşılan bir çift EPDM contasından oluşur. Elemanın vasistaslarının lineer termal genişmesini emer ve ayrıca dahili yük taşıyıcı ızgaranın su ve hava sızdırmazlığını sağlar.

b) örtüşen elemanlar arasında: bu, yeterli kalınlıkta bir iç alüminyum takviyeli termoplastikten yapılmıştır ve üst üste binen tirizlerin iç bölmesine yerleştirilmiştir. Orta tirizlerin lineer genişmesini absorbe eder ve tirizlerin birleşim yerlerinde yapısal devamlılığını garanti eder.

STRUCTURE SPECIFICATIONS

In the FAR WALL system there are various typologies of semistructural, structural, glazed, normal or thermal break curtain walls.

CURTAIN WALLS WITH INDEPENDENT UNITS

The main construction features are an internal load-bearing grid and an external panel or glass bearing unit both made from varnished and anodized EN AW 6060 aluminium alloy T5 hardened and tempered.

Internal load-bearing grid

It consists of a series of independent load-bearing elements, fixed to the building by means of a special fixing system.

The load-bearing elements are connected together by interposing suitable expansion absorbing joints and blocked by means of gauged bolts.

Load-bearing elements

The load-bearing element is the grid made up of mullions and transoms connected together.

The mullions and transoms are coupled by means of self-threading screws (not visible) and thermoplastic interposed joints that guarantee water and air tightness to the load-bearing structure.

The mullions, paired together according to the moments of inertia, have the following dimensions: 70x60 or 70x112 and can be further reinforced by inserting reinforcing profiles in the internal part of the structure. There are two types of transoms depending on the moments of inertia of the curtain wall and the distance between the mullions: 70x77 or 70x129.

Expansion absorbing joints

These are interconnecting elements that are placed in the connection areas between the elements and are necessary for absorbing linear thermal expansion of the aluminium profiles both on the horizontal and vertical axes. Therefore there are two types:

a) between adjacent elements: this consists of a pair of EPDM gaskets that run along mullions of the elements and are shared between the two adjacent elements. It absorbs the linear thermal expansion of the transoms of the element, as well as ensuring water and air tightness of the internal load-bearing grid.

b) between overlapping elements: this is made of thermoplastic with an internal aluminium reinforcement of adequate thickness, and it's inserted in the inner chamber of the overlapping mullions. It absorbs the linear expansion of the mullions, and guarantees the structural continuity of the mullions in the joint areas.



Profil Çeşitleri Types of Profiles

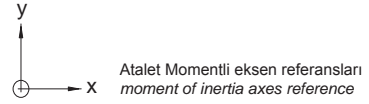

Cam Tutucu 15 MM glazing bead	20.00.022.XX
ağırlık/weight 0.280 (kg/m)	
çevre/perimeter 96.5834 (mm)	
Jx -	
Jy -	

Sabit Kapı Tel Kanat staff bead for fixed wing	20.00.208.XX
ağırlık/weight 0.431 (kg/m)	
çevre/perimeter 128.39 (mm)	
Jx -	
Jy -	

Çift Dikme mm halved mullion	20.00.200.XX
ağırlık/weight 1.866 (kg/m)	
çevre/perimeter 400.302 (mm)	
Jx 7.87 (cm ⁴)	
Jy 109.54 (cm ⁴)	

Açılır tek kanat staff bead for opening wing	20.00.209.XX
ağırlık/weight 0.257 (kg/m)	
çevre/perimeter 104.631 (mm)	
Jx -	
Jy -	

Travers112 mm transom	20.00.202.XX
ağırlık/weight 2.723 (kg/m)	
çevre/perimeter 449.153 (mm)	
Jx 89.31 (cm ⁴)	
Jy 198.37 (cm ⁴)	

Panel Profil profile for pannel	20.00.218.XX
ağırlık/weight 0.52(kg/m)	
çevre/perimeter - (mm)	
Jx -	
Jy -	

Alt Travers 112 mm lower transom	20.00.206.XX
ağırlık/weight 2.280 (kg/m)	
çevre/perimeter 535 (mm)	
Jx 10.51(cm ⁴)	
Jy 125.68 (cm ⁴)	

Süpürgelik skirting	20.00.223.XX
ağırlık/weight 0.557 (kg/m)	
çevre/perimeter 285.51 (mm)	
Jx -	
Jy -	

Üst Travers 2 mm upper transom	20.00.207.XX
ağırlık/weight 2.541 (kg/m)	
çevre/perimeter 448.34 (mm)	
Jx 27.84 (cm ⁴)	
Jy 177.72 (cm ⁴)	

Travers 60 mm transom	20.00.233.XX
ağırlık/weight 1.753 (kg/m)	
çevre/perimeter 342.12 (mm)	
Jx 51.84 (cm ⁴)	
Jy 42.36 (cm ⁴)	

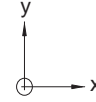

Atalet Momentli eksen referansları
moment of inertia axes reference

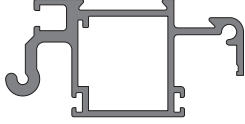
YATAY KANAT PROFİLİ horizontal wing profile 	20.00.235.XX
	ağırlık/weight 1.059 (kg/m)
	çevre/perimeter 302.27 (mm)
	Jx 3.53 (cm ⁴)
Jy 13.00 (cm ⁴)	

CAM TUTUCU 23-26 MM glazing bead 	20.00.255.XX
	ağırlık/weight 0.244 (kg/m)
	çevre/perimeter 86.772 (mm)
	Jx -
Jy -	

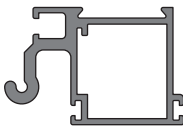
DIKEY KANAT PROFİLİ (profil ile 20.00.235.XX) vertical wing profile (with profile 20.00.235.XX) 	20.00.236.XX
	ağırlık/weight 0.877 (kg/m)
	çevre/perimeter 231.18 (mm)
	Jx 3.28 (cm ⁴)
Jy 6.34 (cm ⁴)	

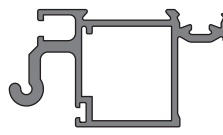
DIKEY KANAT PROFİLİ vertical wing profile 	20.00.259.XX
	ağırlık/weight 0.943 (kg/m)
	çevre/perimeter 261.31 (mm)
	Jx 3.2275 (cm ⁴)
Jy 9.4491 (cm ⁴)	

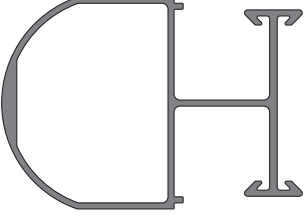
DİKME GÜÇLENDİRME 60 mm reinforcement for mullion 	20.00.237.XX
	ağırlık/weight 2.236(kg/m)
	çevre/perimeter 507.24 (mm)
	Jx 43.04 (cm ⁴)
Jy 89.47(cm ⁴)	

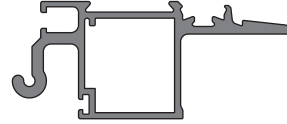
YATAY KANAT PROFİLİ (profil ile 20.00.255.XX o 20.00.281.XX) horizontal wing profile (with profile 20.00.255.XX or 20.00.281.XX) 	20.00.260.XX
	ağırlık/weight 1.083 (kg/m)
	çevre/perimeter 288.5 (mm)
	Jx 3.2388 (cm ⁴)
Jy 16.0836 (cm ⁴)	

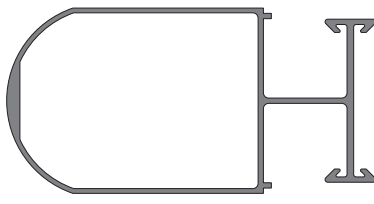
DİKME GÜÇLENDİRME 100 mm reinforcement for mullion 	20.00.238.XX
	ağırlık/weight 2.562(kg/m)
	çevre/perimeter 949.16 (mm)
	Jx 57.74(cm ⁴)
Jy 211.52(cm ⁴)	

Cam Tutucu 28-31 MM glazing bead 	20.00.281.XX
	ağırlık/weight 0.299 (kg/m)
	çevre/perimeter 103.69 (mm)
	Jx -
Jy -	

Köşe corner 	20.00.248.XX
	ağırlık/weight 1.46 (kg/m)
	çevre/perimeter 285.72 (mm)
	Jx -
Jy -	

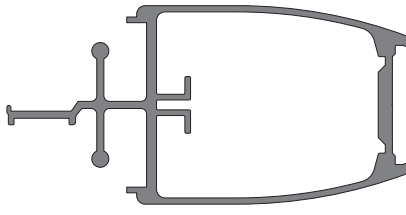
dikme mullion 	20.00.282.XX
	ağırlık/weight 3.568 (kg/m)
	çevre/perimeter 537.73 (mm)
	Jx 65.10 (cm ⁴)
Jy 224.55 (cm ⁴)	

Profil Çeşitleri List of profiles

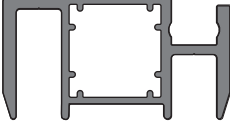

Kapalı dikme 60 mm <i>closed mullion</i>	20.00.283.XX
	ağırlık/weight 1.384 (kg/m)
	çevre/perimeter 296.10 (mm)
	Jx 4.88 (cm ⁴)
	Jy 21.88 (cm ⁴)

Üst Travers 60 mm <i>upper transom</i>	20.00.291.XX
	ağırlık/weight 1.49 (kg/m)
	çevre/perimeter 391 (mm)
	Jx 6.27 (cm ⁴)
	Jy 24.88 (cm ⁴)

Alt Travers 60 mm <i>lower transom</i>	20.00.292.XX
	ağırlık/weight 2.06 (kg/m)
	çevre/perimeter 424.51 (mm)
	Jx 24.35 (cm ⁴)
	Jy 45.48 (cm ⁴)

Profil Çeşitleri List of profiles



ISI YALITIMLI KANAT PROFİLLERİ List of thermal break wing profiles

ÖNEMLİ NOT:

Çubukların anormal deformasyonunu önlemek için montajdan (haddeleme) önce profiller üzerinde işlem (boyama, oksidasyon vb.) yapın.

MKAV TT20 CAM TUTUCU wing (20mm bars)	22.00.026.XX
	ağırlık/weight 1.482 (kg/m)
	çevre/perimeter 337.07 (mm)
	Jx 3.55 (cm ⁴)
	Jy 32.30 (cm ⁴)

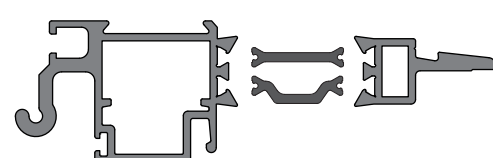
21.00.024.XX		21.00.025.XX	
ağırlık/weight 0.945 (kg/m)	çevre 257.99 (mm)	ağırlık/weight 0.382 (kg/m)	çevre 109.72 (mm)
			

TÛM CAMLAR wing (20mm bars)	22.00.029.XX
	ağırlık/weight 1.332 (kg/m)
	çevre/perimeter 301.61 (mm)
	Jx 3.44 (cm ⁴)
	Jy 20.54 (cm ⁴)

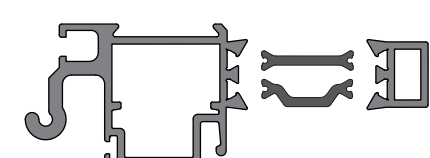
21.00.024.XX		21.00.028.XX	
ağırlık/weight 0.945 (kg/m)	çevre 257.99 (mm)	ağırlık/weight 0.239 (kg/m)	çevre 74.55 (mm)
			

TERMİK KAPI KANADI (ÇUBUK 15mm) List of thermal break wing profiles

MKAV TT15 DİKEY KANAT vertical wing (15mm bars)	22.00.285.XX
	ağırlık/weight 1.582 (kg/m)
	çevre/perimeter 365.18 (mm)
	Jx 4.78 (cm ⁴)
	Jy 30.12 (cm ⁴)

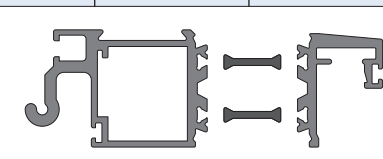
21.00.659.XX		21.00.662.XX	
ağırlık/weight 0.992 (kg/m)	çevre 246.40 (mm)	ağırlık/weight 0.499 (kg/m)	çevre 171.36 (mm)
			

MKAV TT15A TERMAL KANAT thermal break wing (15mm bars)	22.00.287.XX
	ağırlık/weight 1.658 (kg/m)
	çevre/perimeter 373.66 (mm)
	Jx 4.93 (cm ⁴)
	Jy 37.87 (cm ⁴)

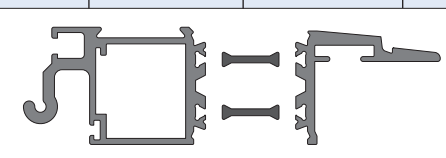
21.00.659.XX		21.00.679.XX	
ağırlık/weight 0.992 (kg/m)	çevre 246.40 (mm)	ağırlık/weight 0.575 (kg/m)	çevre 179.69 (mm)
			

TERMAL SİSTEMLİ KANAT PROFİLLERİ (ÇUBUK 10mm)

List of thermal break wing profiles

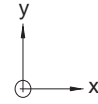

Atalet Momentli eksen referansları
moment of inertia axes reference

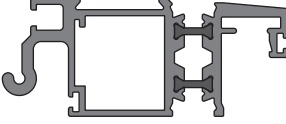
<p>MKAV TT10 DİKEY KANAT vertical wing (10mm bars)</p> 	22.00.214.XX
	ağırlık/weight 1.557 (kg/m)
	çevre/perimeter 355.18 (mm)
	Jx 4.78 (cm ⁴)
Jy 25.36 (cm ⁴)	

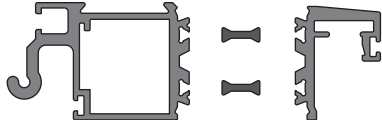
21.00.659.XX		21.00.662.XX	
ağırlık/weight 0.992 (kg/m)	çevre 246.40 (mm)	ağırlık/weight 0.499 (kg/m)	çevre 171.36 (mm)
			

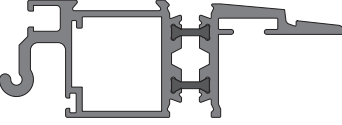
<p>MKAV TT10 A TUTUCU thermal break wing (10mm bars)</p> 	22.00.254.XX
	ağırlık/weight 1.633 (kg/m)
	çevre/perimeter 363.66 (mm)
	Jx 4.93(cm ⁴)
Jy 32.17 (cm ⁴)	

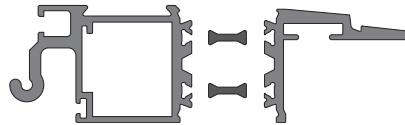
21.00.659.XX		21.00.679.XX	
ağırlık/weight 0.992 (kg/m)	çevre 246.40 (mm)	ağırlık/weight 0.575 (kg/m)	çevre 179.69 (mm)
			



Profil Ölçekleri Scale Profiles

DİKME PROFİLLER
Mullion profiles

20.00.200.XX
ağırlık/weight Kg/m 1.866

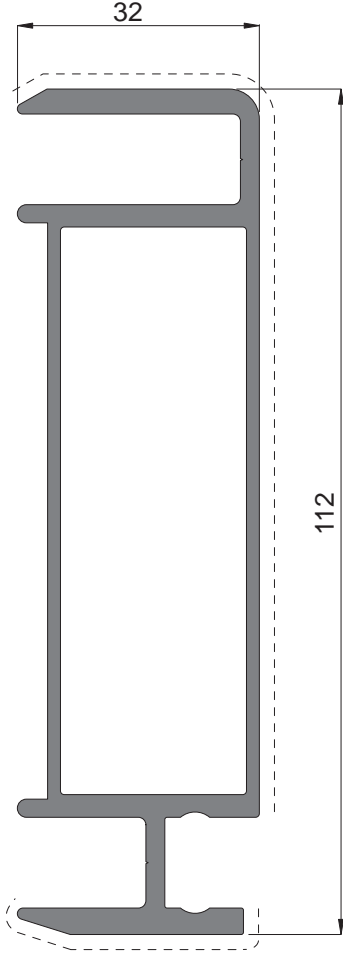

20.00.283.XX
ağırlık/weight Kg/m 1.384

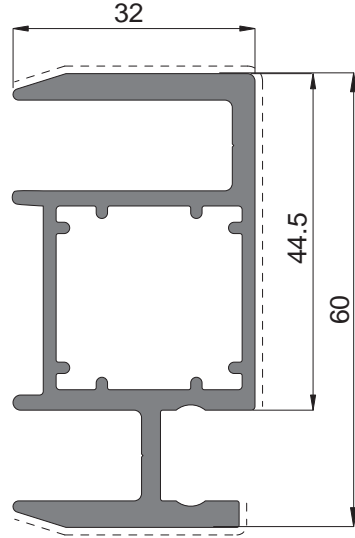

20.00.208.XX
ağırlık/weight Kg/m 0.431

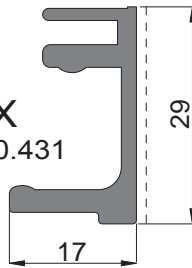

20.00.209.XX
ağırlık/weight Kg/m 0.257

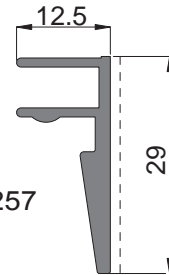

ORTA PROFİL İÇİN GÜÇLENDİRİCİ
Stiffener for mullion profiles

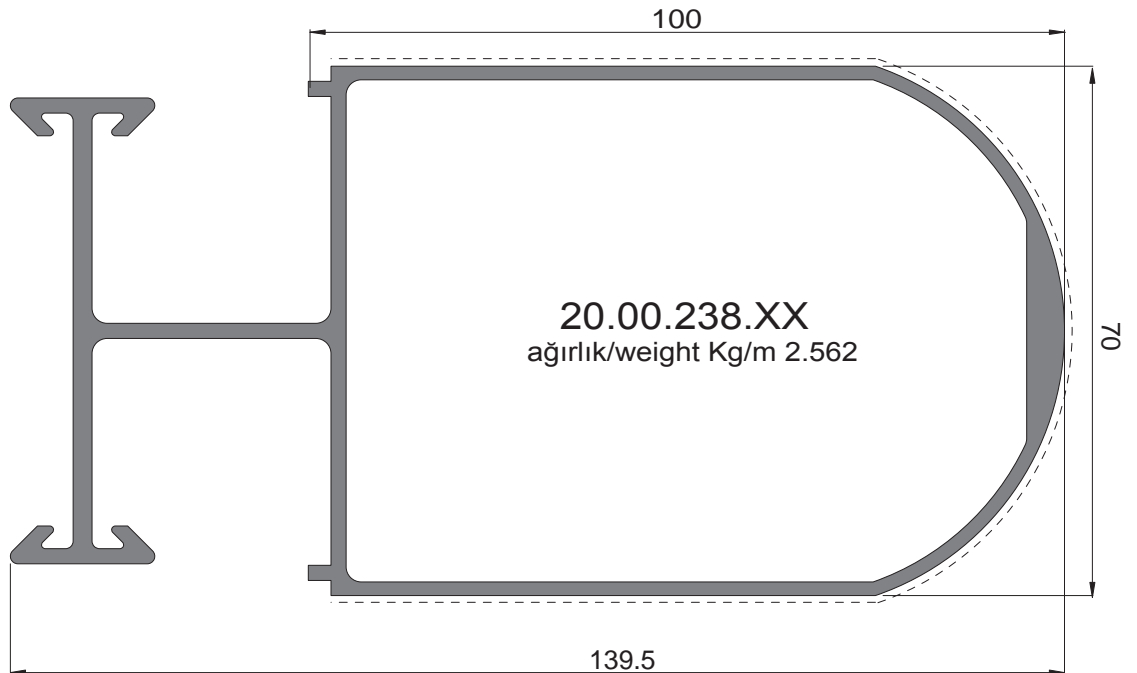
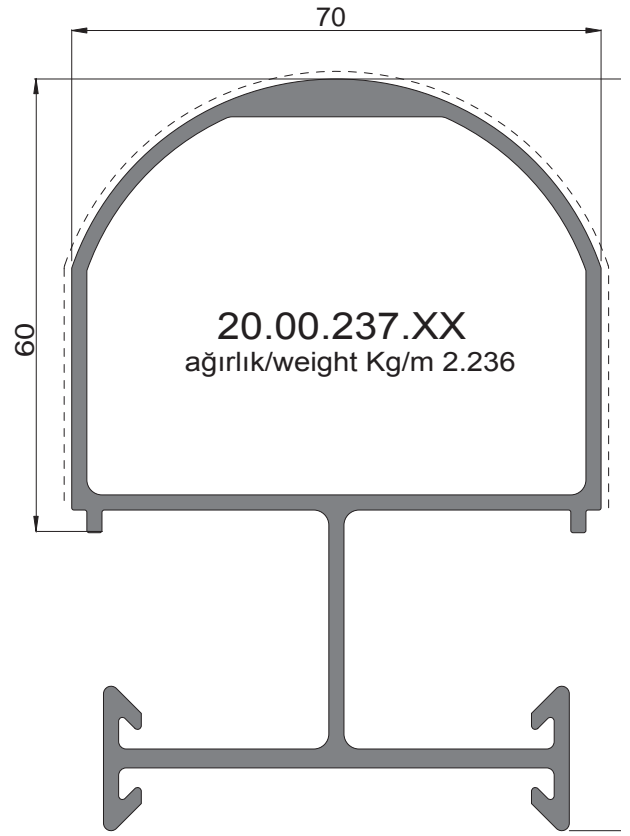
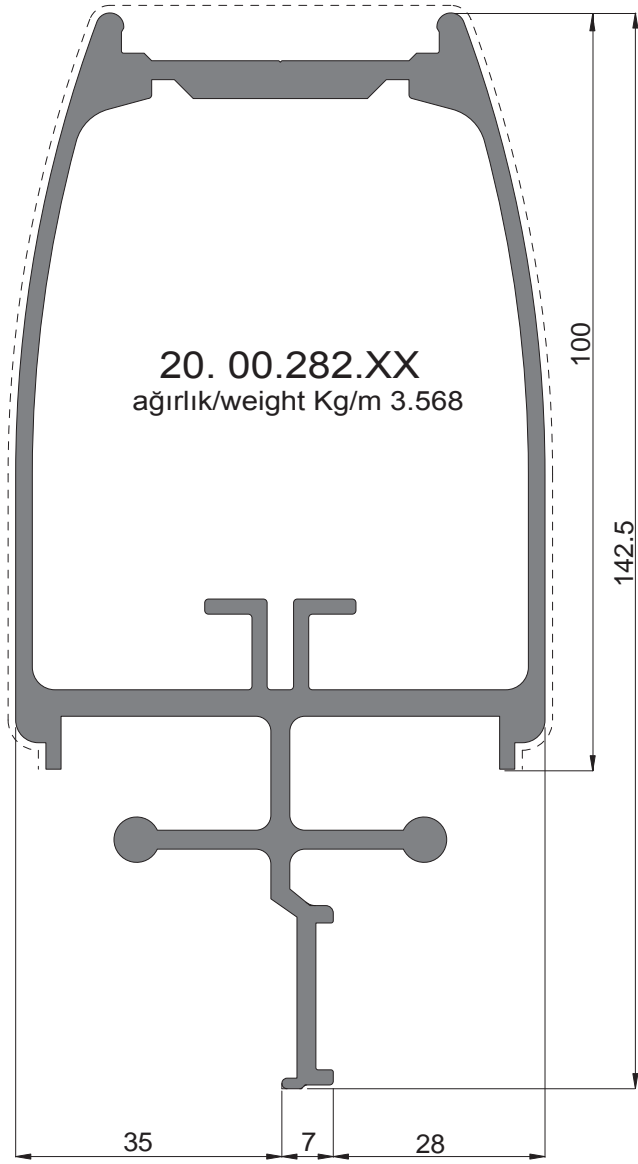

PROFİLLER
profiles

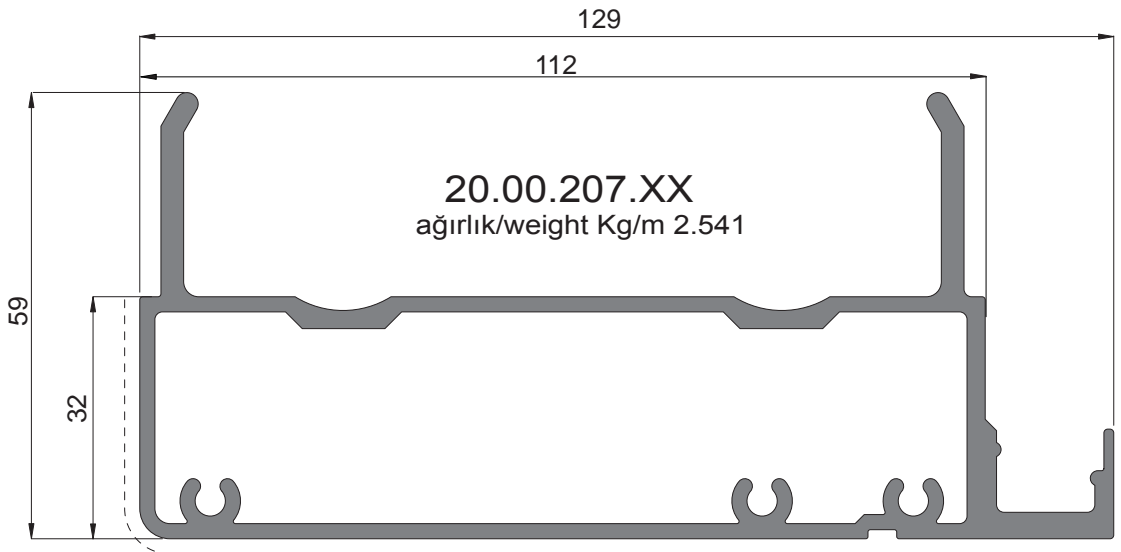
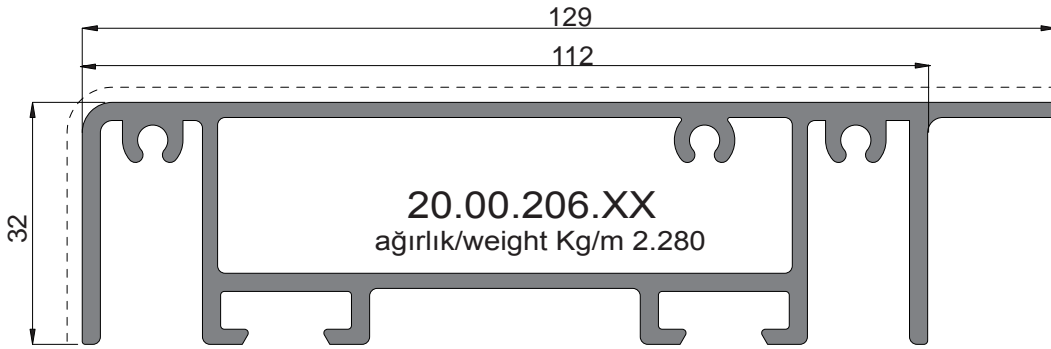
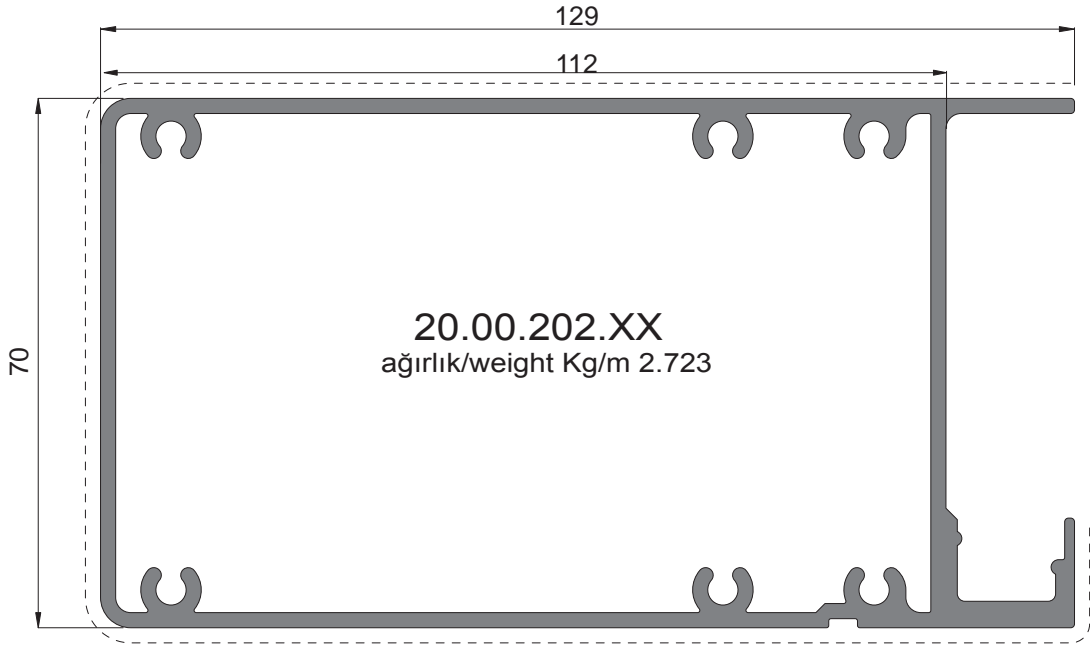

PROFİLLER
Profiles

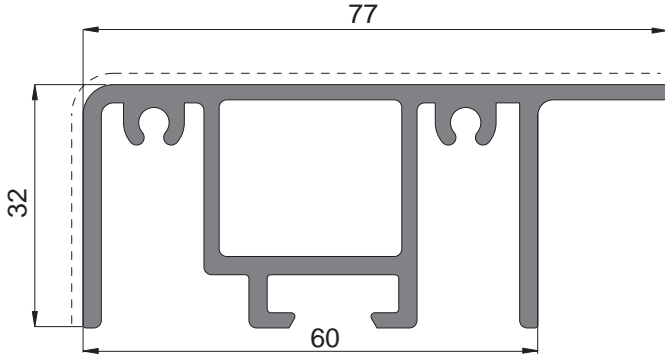

20.00.291.XX
ağırlık/weight Kg/m 1.49

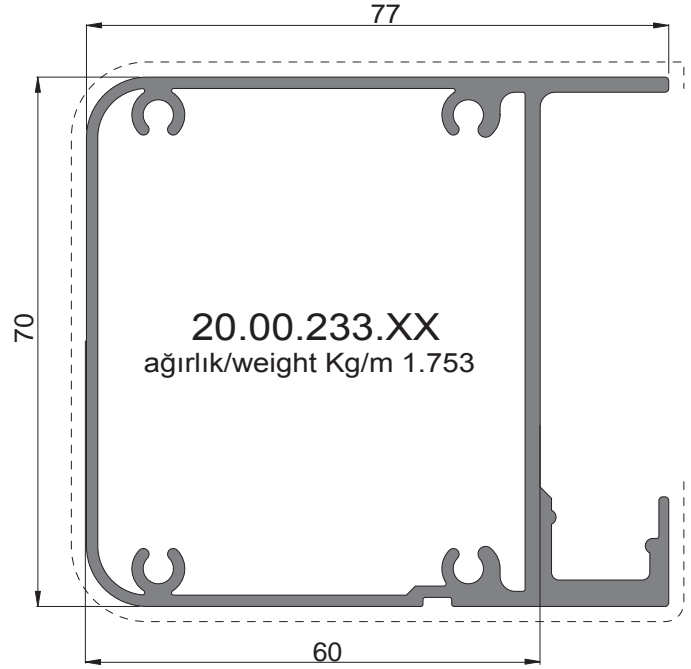

20.00.233.XX
ağırlık/weight Kg/m 1.753

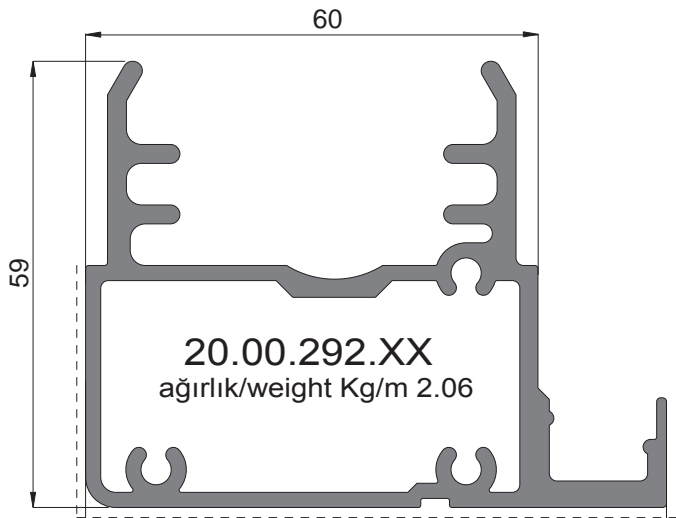

20.00.292.XX
ağırlık/weight Kg/m 2.06

ÇERÇEVE PROFİLİ
Frame profiles

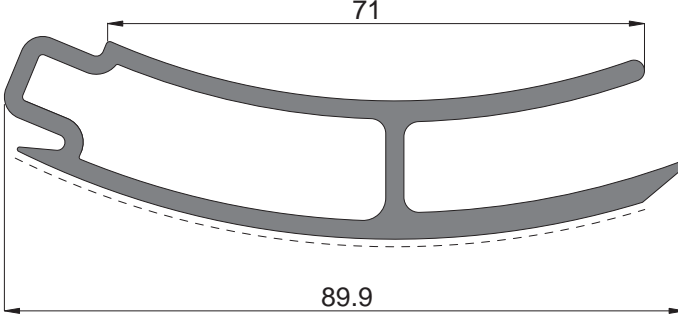

20.00.248.XX
ağırlık/weight Kg/m 1.46

TEL KAPAK PROFİLLERİ
Staff bead profiles

20.00.218.XX
ağırlık/weight Kg/m 0.520

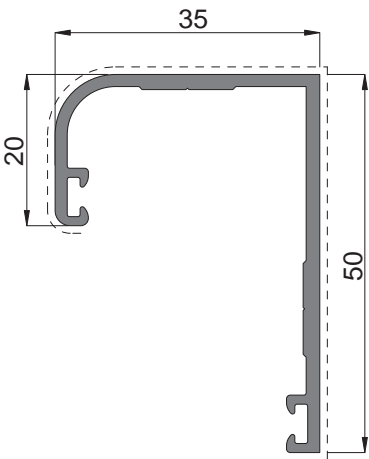

20.00.223.XX
ağırlık/weight Kg/m 0.557

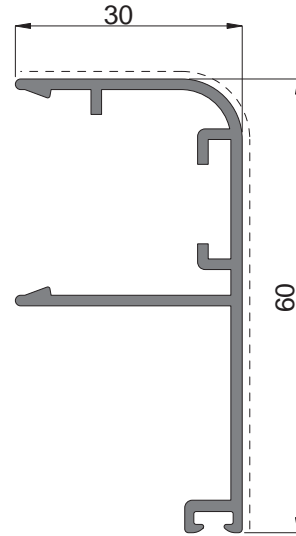

TERMAL SİSTEM KANAT PROFİLLERİ (çubuk 20mm)
Thermal break wing profiles (20mm bars)

22.00.026.XX
ağırlık/weight Kg/m 1.461

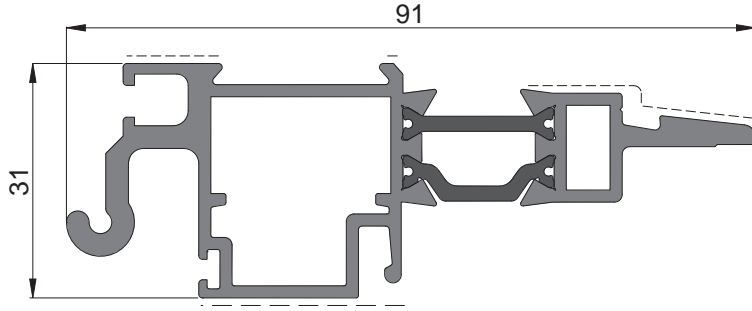

22.00.029.XX
ağırlık/weight Kg/m 1.318

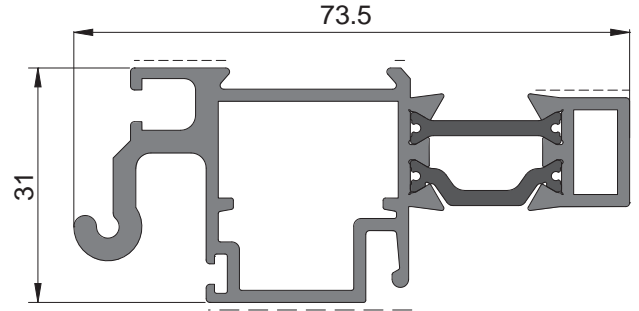

TERMAL SİSTEM KANAT PROFİLLERİ (çubuk 10mm)
Thermal break wing profiles (10mm bars)

22.00.214.XX
ağırlık/weight Kg/m 1.557

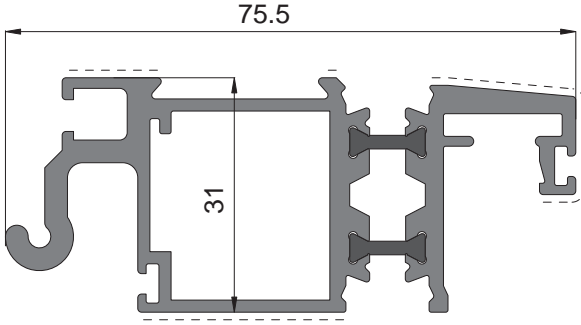

22.00.254.XX
ağırlık/weight Kg/m 1.633

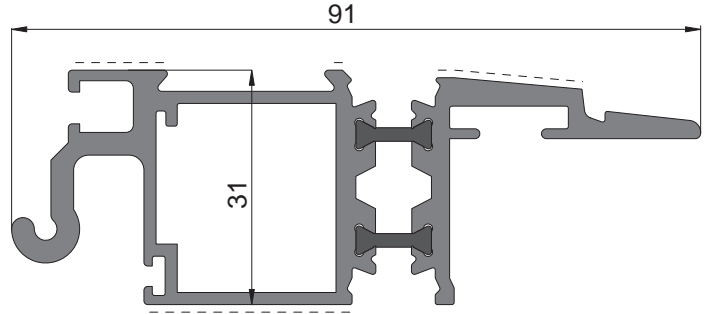

TERMAL SİSTEM KANAT PROFİLLERİ (çubuk 15mm)
Thermal break wing profiles (15mm bars)

22.00.285.XX
ağırlık/weight Kg/m 1.582

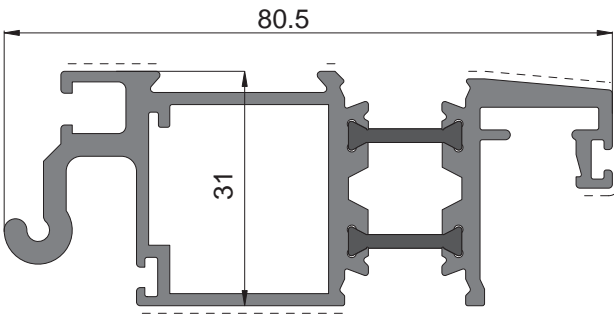

22.00.287.XX
ağırlık/weight Kg/m 1.658

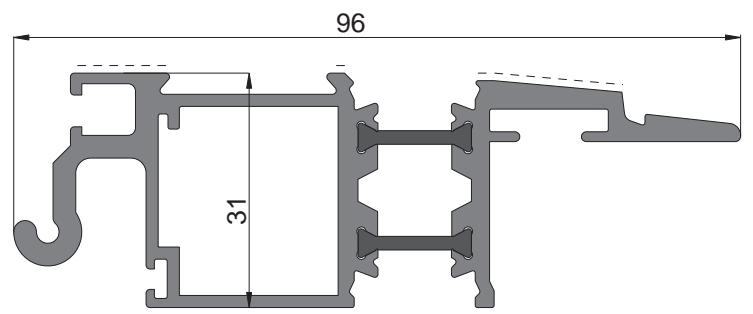

KANAT PROFİLLERİ

Wing profiles

20.00.235.XX

ağırlık/weight Kg/m 1.059

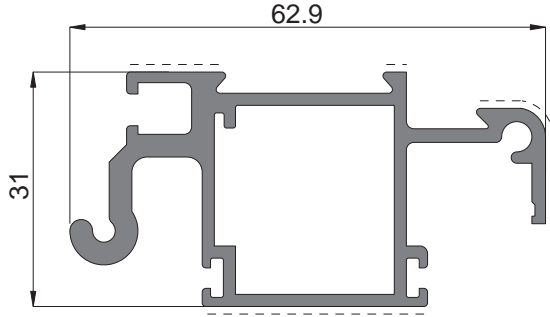

20.00.236.XX

ağırlık/weight Kg/m 0.877

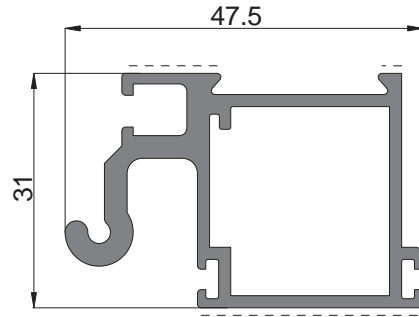

20.00.259.XX

ağırlık/weight Kg/m 0.943

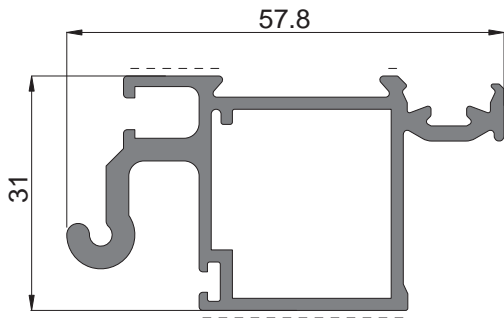

20.00.260.XX

ağırlık/weight Kg/m 1.083

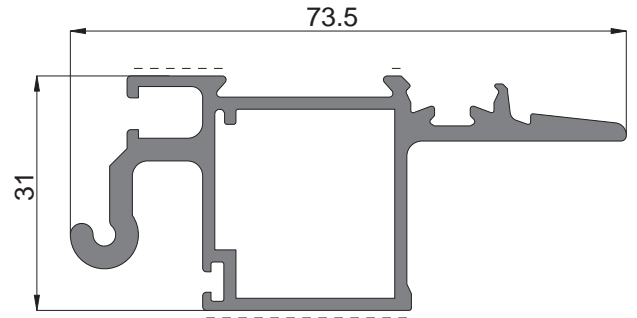

TUTUCU
Glazing bead

20.00.022.XX
ağırlık/weight Kg/m 0.28

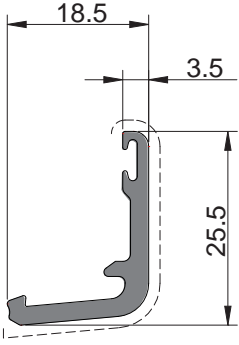

20.00.255.XX
ağırlık/weight Kg/m 0.244

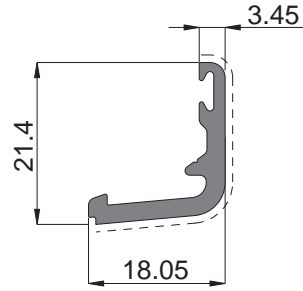

20.00.281.XX
ağırlık/weight Kg/m 0.299

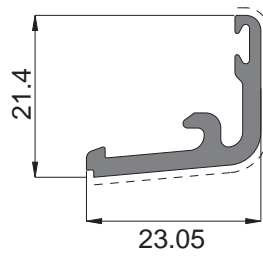



Aksesuarlar Accessories

ÜRÜN KODU <i>code</i>	ÜRÜN ADI <i>description</i>	RESİM <i>picture</i>
02.11.003.XX	Köşe Körleme <i>corner groove covering</i>	
02.11.006.00	Köşe Birleştirme 23.2x12.6 mm (MKAV TT20) <i>corner</i>	
02.11.007.00	Köşe Birleştirme 5.3x10.7 mm (MKAV TT20) <i>corner</i>	
02.11.116.00	Köşe Birleştirme (MKAV TT10/15) <i>alignment corner</i>	
02.11.118.00	Köşe 25mm 60°-120° (dikey TT10/15) <i>variable corner for sashes 60°-120° 25mm clearance (vertical)</i>	

ÜRÜN KODU <i>code</i>	ÜRÜN ADI <i>description</i>	RESİM <i>picture</i>
02.11.146.00	Köşe 25mm (MKAV TT10/15) <i>corner for 25mm clearance</i>	
02.11.147.00	Köşe 25mm arası derecelerde mevcut 60°-120° (TT10/15) <i>variable corner for angles between 60°-120 ° and 25mm clearance</i>	
02.11.148.00	Köşe travers 60° - 120° <i>variable corner for transom 60°-120°</i>	
09.11.008.00	Köşe 25 mm (MKAV TT10/15) <i>corner</i>	
02.12.130.XX 02.12.130.64	Dışa açma kolu <i>outward opening handle</i>	





ÜRÜN KODU <i>code</i>	ÜRÜN ADI <i>description</i>	RESİM <i>picture</i>
09.12.140.00	Kanat Dışa Açma Motoru <i>motor for outward opening sash</i>	
09.12.142.74	Dereceli Kanat Dışa Açma Motoru <30° <i>chain operator for outward opening sash</i>	
02.14.120.00	Birleştirme contası çift (prof. 20.00.202.XX) <i>pair of joint gaskets</i>	
02.14.124.00	dikme için conta (prof. 20.00.200.XX) <i>gaskets joint for mullion</i>	
02.14.129.00	Universal çift conta bağlantı <i>pair of universal joint gaskets</i>	



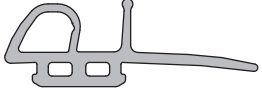
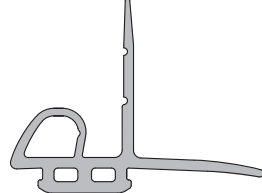

ÜRÜN KODU <i>code</i>	ÜRÜN ADI <i>description</i>	RESİM <i>picture</i>
02.14.131.00	Birleştirme contası çift (prof. 20.00.207.XX) <i>pair of joint gaskets</i>	
02.14.132.00	Birleştirme contası çift (prof. 20.00.206.XX) <i>pair of joint gaskets</i>	
02.14.133.00	Birleştirme contası çift (prof. 20.00.200.XX) <i>pair of joint gaskets</i>	
02.14.137.00	Birleştirme contası çift FAR WALL <i>pair of joint gaskets</i>	
02.14.138.00	Birleştirme contası çift <i>pair of joint gaskets</i>	



ÜRÜN KODU code	ÜRÜN ADI description	RESİM picture
02.14.155.00	Çapraz çift conta <i>pair of joint gaskets on transom</i>	
02.14.157.00	Dikey hizalama aparatu 60 mm <i>joint alignment for mullion</i>	
02.16.007.00	paslanmaz cam destek aparatu (prof. 22.00.029.XX) <i>stainless steel glass support</i>	
02.16.119.00	Kanat Stoperi <i>snubber for sash</i>	
02.16.123.00	Naylon Mentеше <i>nylon hinge</i>	

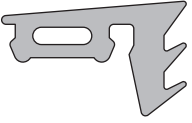

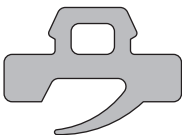

ÜRÜN KODU code	ÜRÜN ADI description	RESİM picture
02.16.145.00	Dış Harici Klip <i>external clip to block a sash (used on jambs)</i>	
02.16.156.00	Paslanmaz cam destek aparati (prof. 22.00.267.XX e 22.00.268.XX) <i>stanless steel glass support</i>	
02.24.125.00	Galvaniz çelik bağlantı aparati <i>galvanized steel bracket</i>	
02.24.126.00	Dikmeler için ankor kit <i>anchorage kit for mullion</i>	
02.24.135.00	Somun M12x90 galvaniz <i>M12x90 galvanized bolt</i>	

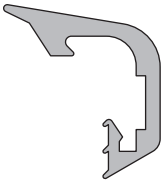
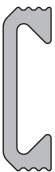

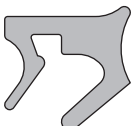
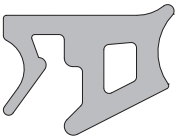
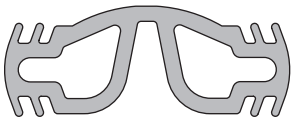
ÜRÜN KODU <i>code</i>	ÜRÜN ADI <i>description</i>	RESİM <i>picture</i>
02.24.139.00	Dikmeler için dişli ankor kit <i>anchorage kit for mullion with threaded inserts</i>	
02.24.158.00	Mobil taban aparatı 60mm <i>mobile base with 60mm rule</i>	
00.05.105.00	Yarıklı Pim 20.00.022.XX <i>sicurity plug for glazing bead</i>	
00.06.182.00	Kılavuzlu Civata TC EI 4.8X50 <i>self-tapping screw</i>	

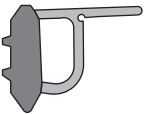
ÜRÜN KODU <i>code</i>	ÜRÜN ADI <i>description</i>	RESİM <i>picture</i>
00.40.046.00	Orta Conta MKAV TT20 <i>middle gasket</i>	
00.40.047.00	Dudaklı orta Conta MKAV TT20 <i>middle gasket with long lip</i>	
00.40.058.00	Köşe Conta 2 mm <i>2mm wedge gasket</i>	
00.40.059.00	Köşe Conta 3 mm <i>3mm wedge gasket</i>	
00.40.060.00	Köşe Conta 4 mm <i>4mm wedge gasket</i>	
00.40.061.00	Köşe Conta 5 mm <i>5mm wedge gasket</i>	

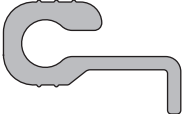
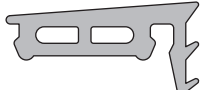
ÜRÜN KODU <i>code</i>	ÜRÜN ADI <i>description</i>	RESİM <i>picture</i>
00.40.734.00	Sızdırmazlık İç Conta 26mm cam <i>glazing gasket inside for 26 mm glass</i>	
00.40.735.00	Sızdırmazlık İç Conta 23mm cam <i>glazing gasket inside for 23 mm glass</i>	
00.40.817.00	Dikme Contası (radüslü perde duvar) <i>connection mullion gasket (radius curtain wall)</i>	
00.40.853.00	Orta Gasket <i>middle gasket</i>	
00.40.856.00	Ayırma Conta <i>split transom gasket</i>	
00.40.858.00	Dikme bağlantı contası <i>connection mullion gasket</i>	
00.40.859.00	Kanat Kilit Contası <i>locking gasket for wing connection profile</i>	

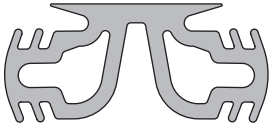
ÜRÜN KODU <i>code</i>	ÜRÜN ADI <i>description</i>	RESİM <i>picture</i>
00.40.863.00	Dış Cam Conta prof. 20.00.235.XX <i>external glazing gasket</i>	
00.40.868.00	Dikme Güçendirme Contası <i>stiffener mullion gasket</i>	
00.40.869.00	İç Sızdırmazlık Contası 8 mm <i>internal glazing gasket</i>	
00.40.870.00	İç Sızdırmazlık Contası 10 mm <i>internal glazing gasket</i>	
00.40.871.00	İç Sızdırmazlık Contası 12 mm <i>internal glazing gasket</i>	
00.40.872.00	İç Sızdırmazlık Contası 15 mm <i>internal glazing gasket</i>	
00.40.882.00	Dikme Contası (radüslü perde duvar) <i>connection mullion gasket (radius curtain wall)</i>	

ÜRÜN KODU <i>code</i>	ÜRÜN ADI <i>description</i>	RESİM <i>picture</i>
00.40.889.00	Dış Cam Conta <i>external glazing gasket</i>	
00.40.903.00	Orta Conta Çeşitli Açılarda <i>middle gasket for variable angles</i>	
00.40.909.00	Orta Conta Termal MKAV TT 15mm <i>middle gasket for sash with 15mm thermal break</i>	
00.40.908.00	Profil Contası art. 20.00.282.XX <i>gasket for profile 20.00.282.XX</i>	
00.40.910.00	İç sızdırmazlık Contası MKAV TT 15mm Cam <i>inside glazing gasket for sash with 15 mm thermal break</i>	
00.40.917.00	Orta Conta Çeşitli Açılarda <i>middle gasket for variable angles</i>	
00.40.918.00	Dikme Bağlantı Contası (radüslü perde duvar 4°) <i>connection mullion gasket (4° radius curtain wall)</i>	

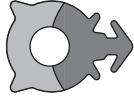
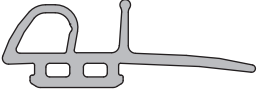
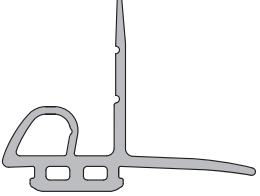
ÜRÜN KODU <i>code</i>	ÜRÜN ADI <i>description</i>	RESİM <i>picture</i>
00.43.001.00	İç Cam Conta <i>internal glazing gasket</i>	
00.44.822.00	İç Kanat Conta <i>inside sash gasket</i>	
00.51.829.00	İç Conta <i>inside sash gasket</i>	
00.54.046.00	Orta Conta MKAV TT20 <i>middle gasket</i>	
00.54.047.00	Yüzgeçli ara Conta Uzun Dudak MKAV TT20 <i>middle gasket with long lip</i>	



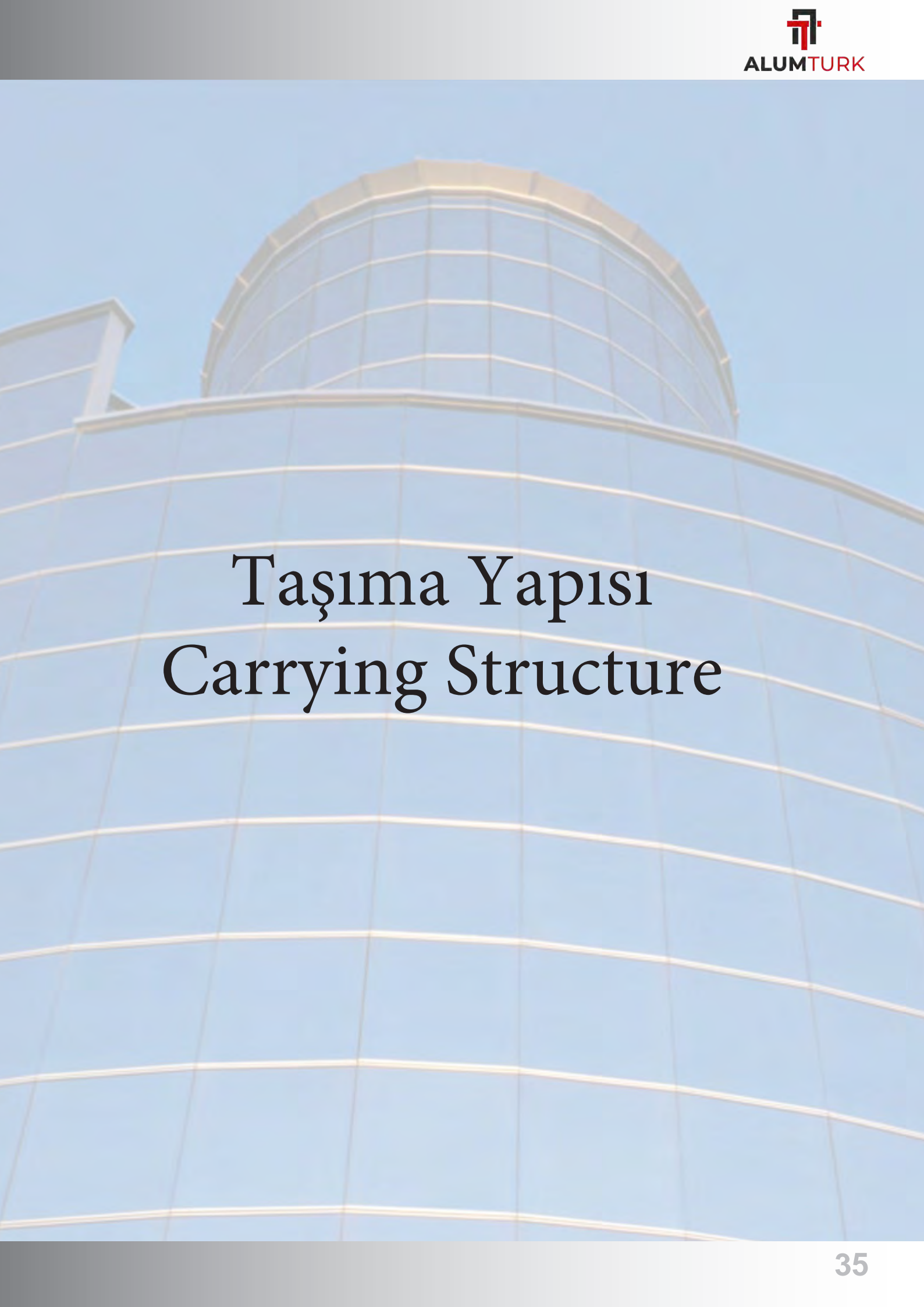

Taşıma Yapısı Carrying Structure

CEPHE TÜRLERİ
Front typologies

YATAY BÖLÜM

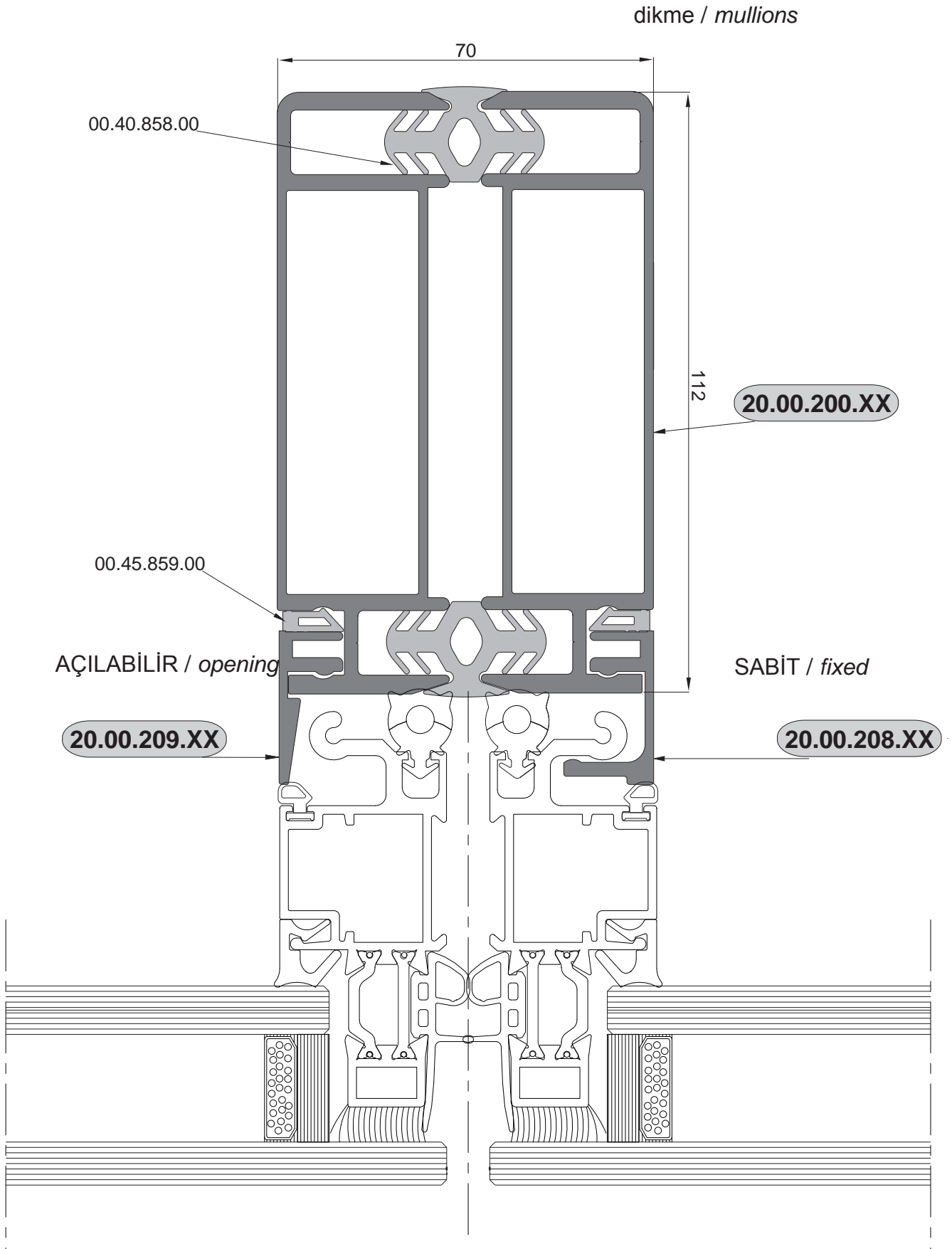

KÖŞELER
Corners

KÖŞELER / corner 10° 00.40.858.00

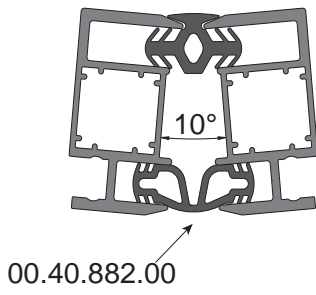
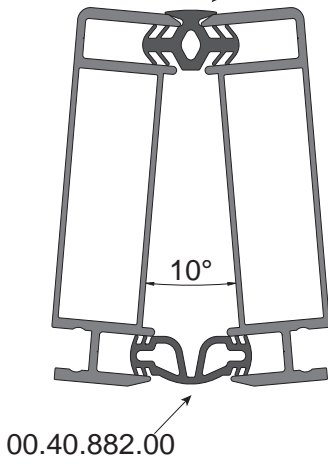

KÖŞELER / corner 20° 00.40.858.00

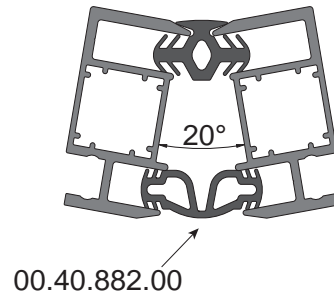
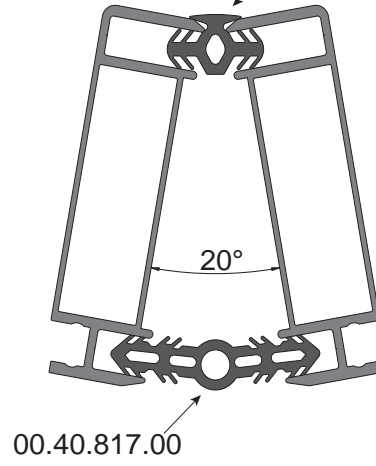

KÖŞELER / corner 45° - 90°

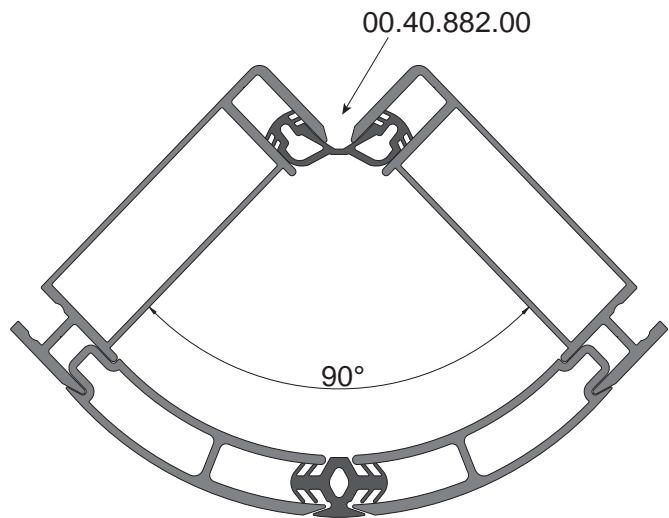
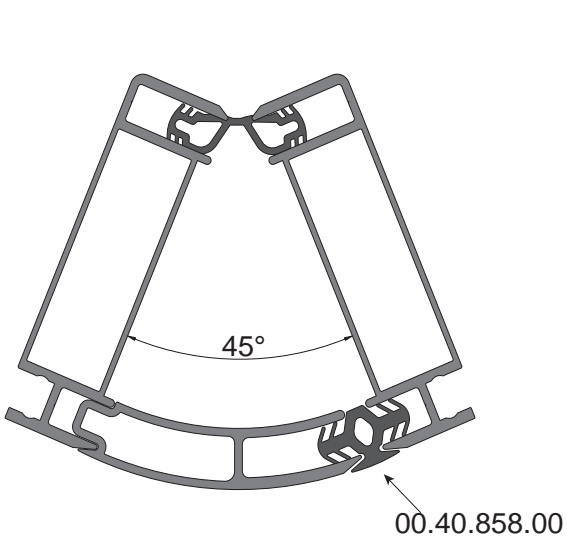

KÖŞELER
Corners

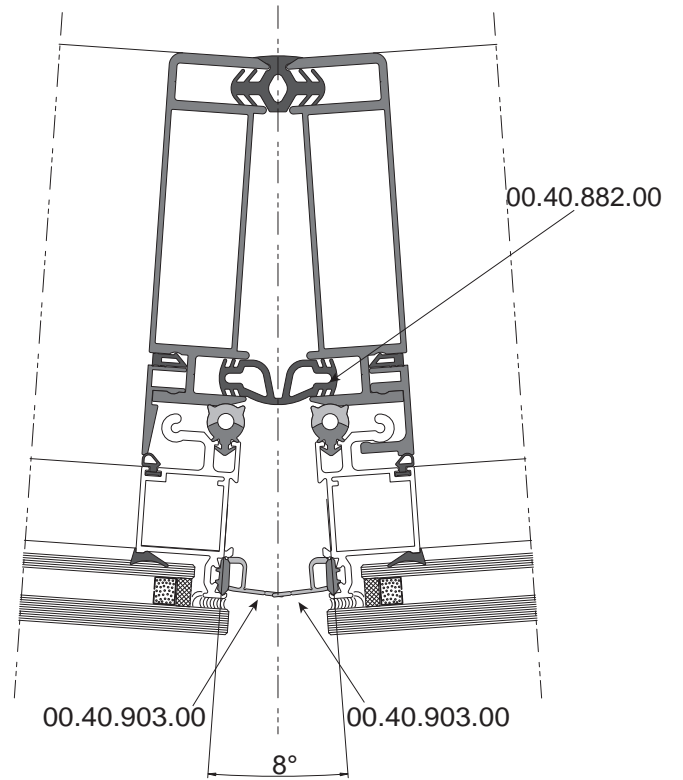
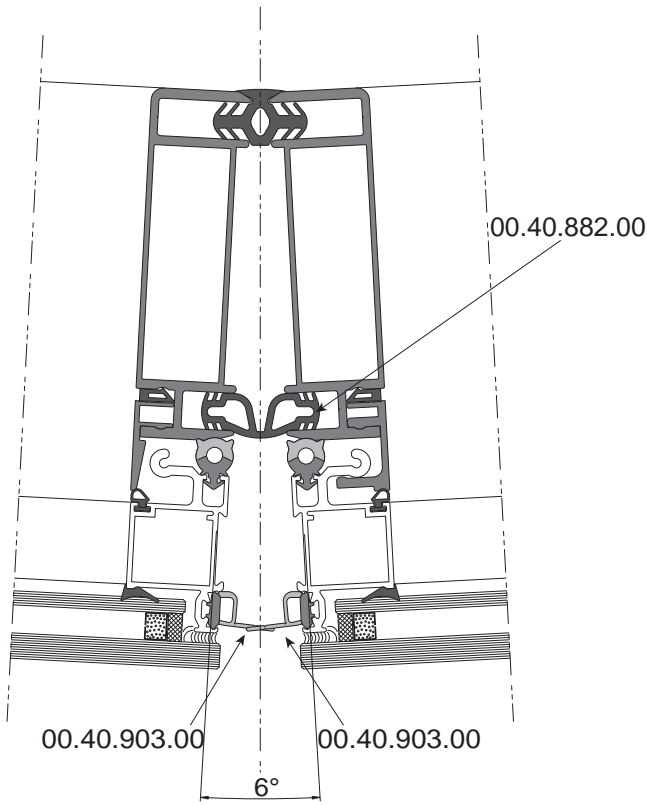
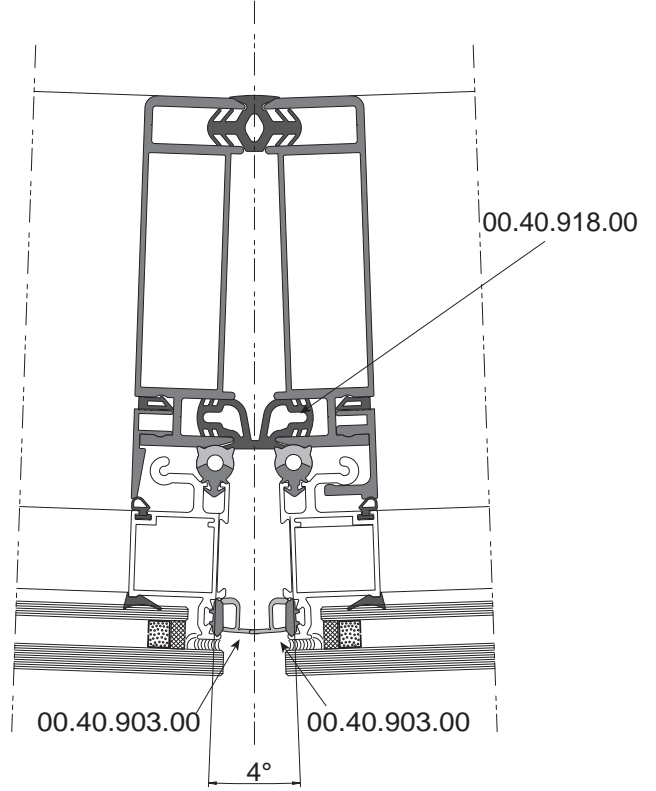
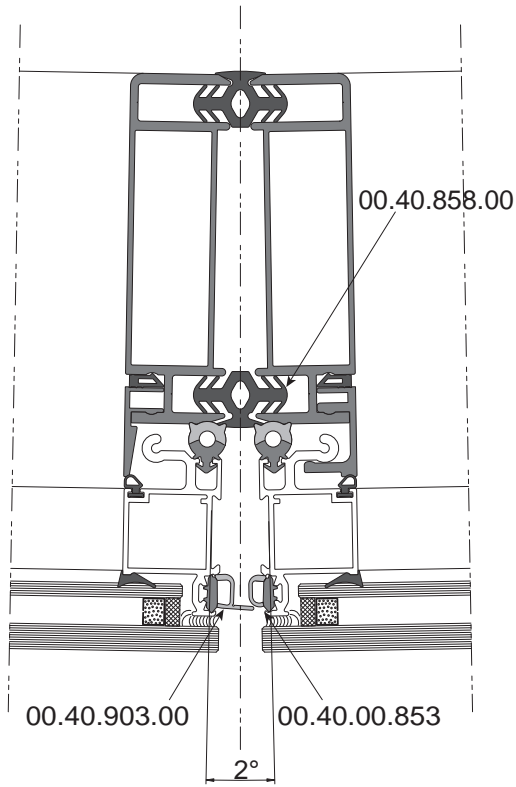



Takımlar Tools

DİKME TAKIMLARI KODU 20.00.200.XX
Tooling for mullion code 20.00.200.XX

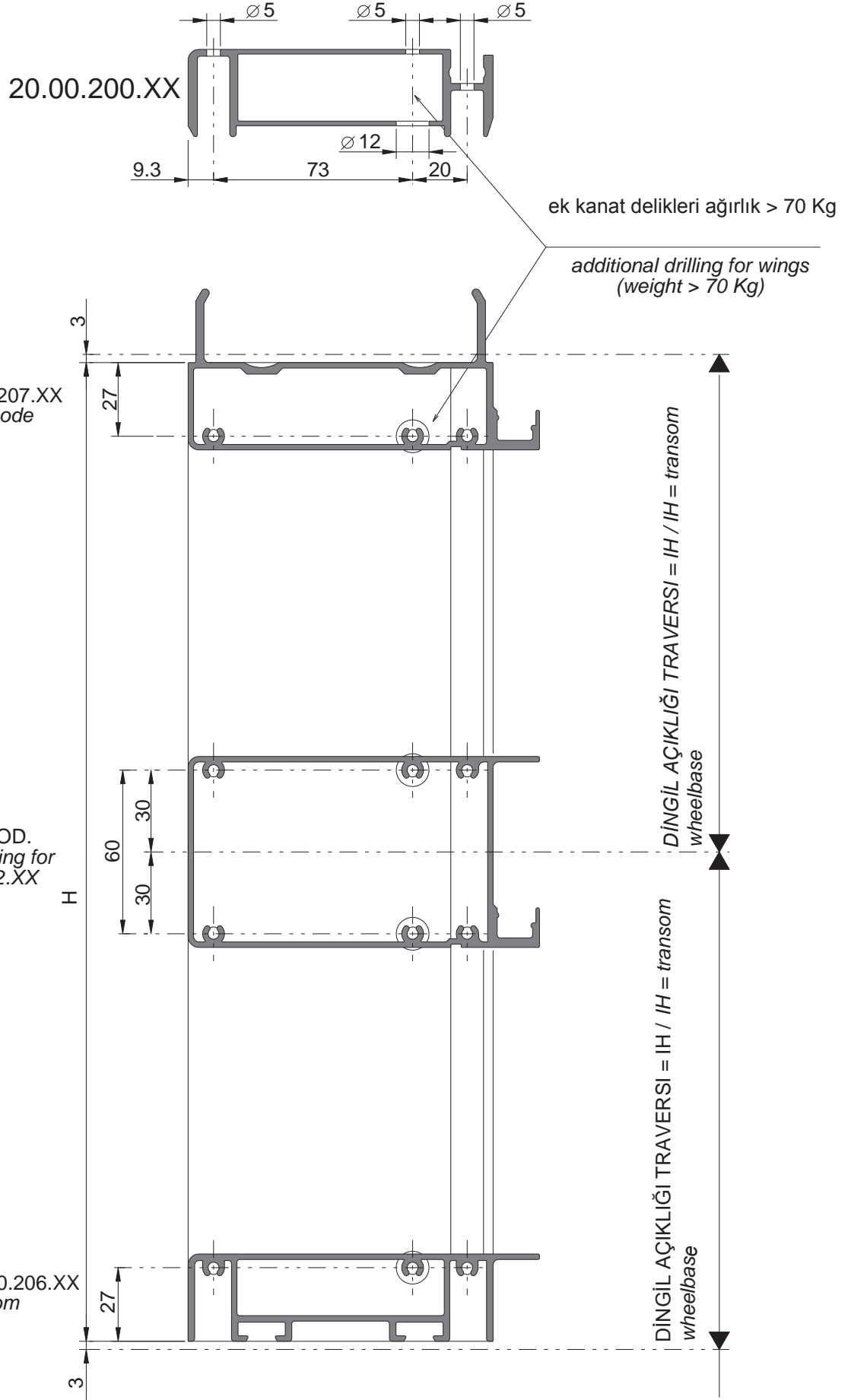

DİKMELERDE MONTAJ PARÇASI KOD. 20.00.200.XX
Assembling transoms on mullion code 20.00.200.XX

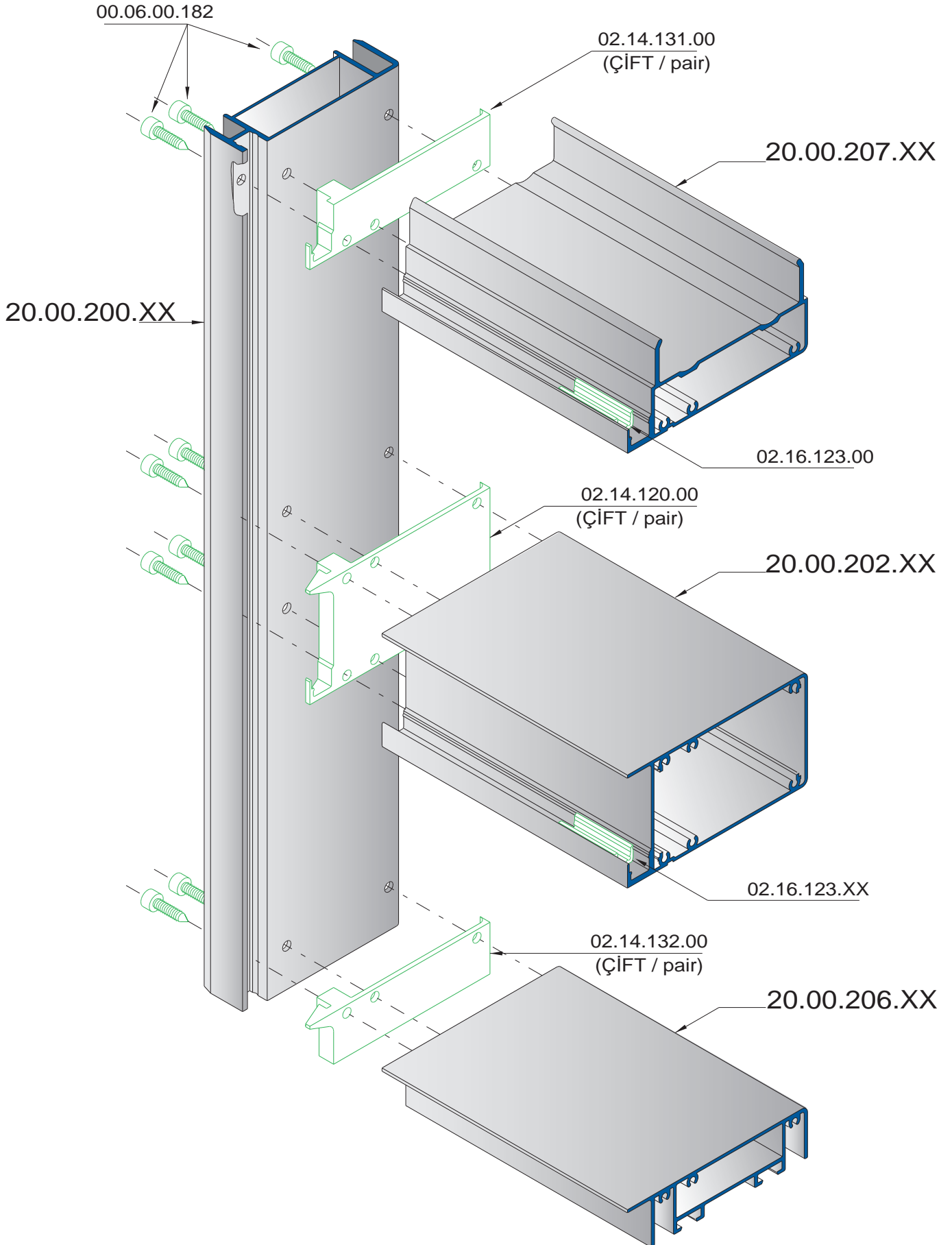

DİKME TAKIM KOD. 20.00.200.XX
 Tooling for mullion code 20.00.200.XX

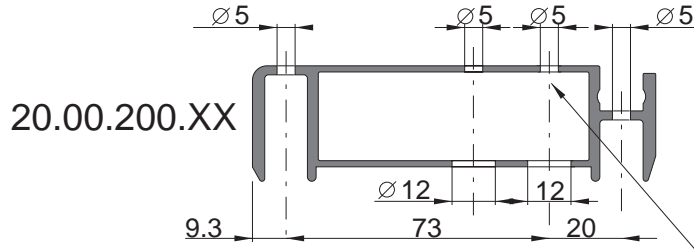

EK DELİK KANAT İÇİN ağırlık > 70 Kg

additional drilling for wings
 (weight > 70 Kg)

ÜST TAKIM DİKME İÇİN
 KOD. 20.00.207.XX
 upper tooling for transom
 code 20.00.207.XX

ORTA TAKIM DİKME İÇİN
 KOD. 20.00.233.XX
 middle tooling for transom
 code 20.00.233.XX

ALT TAKIM DİKME İÇİN
 KOD. 20.00.206.XX
 lower tooling for transom
 code 20.00.206.XX

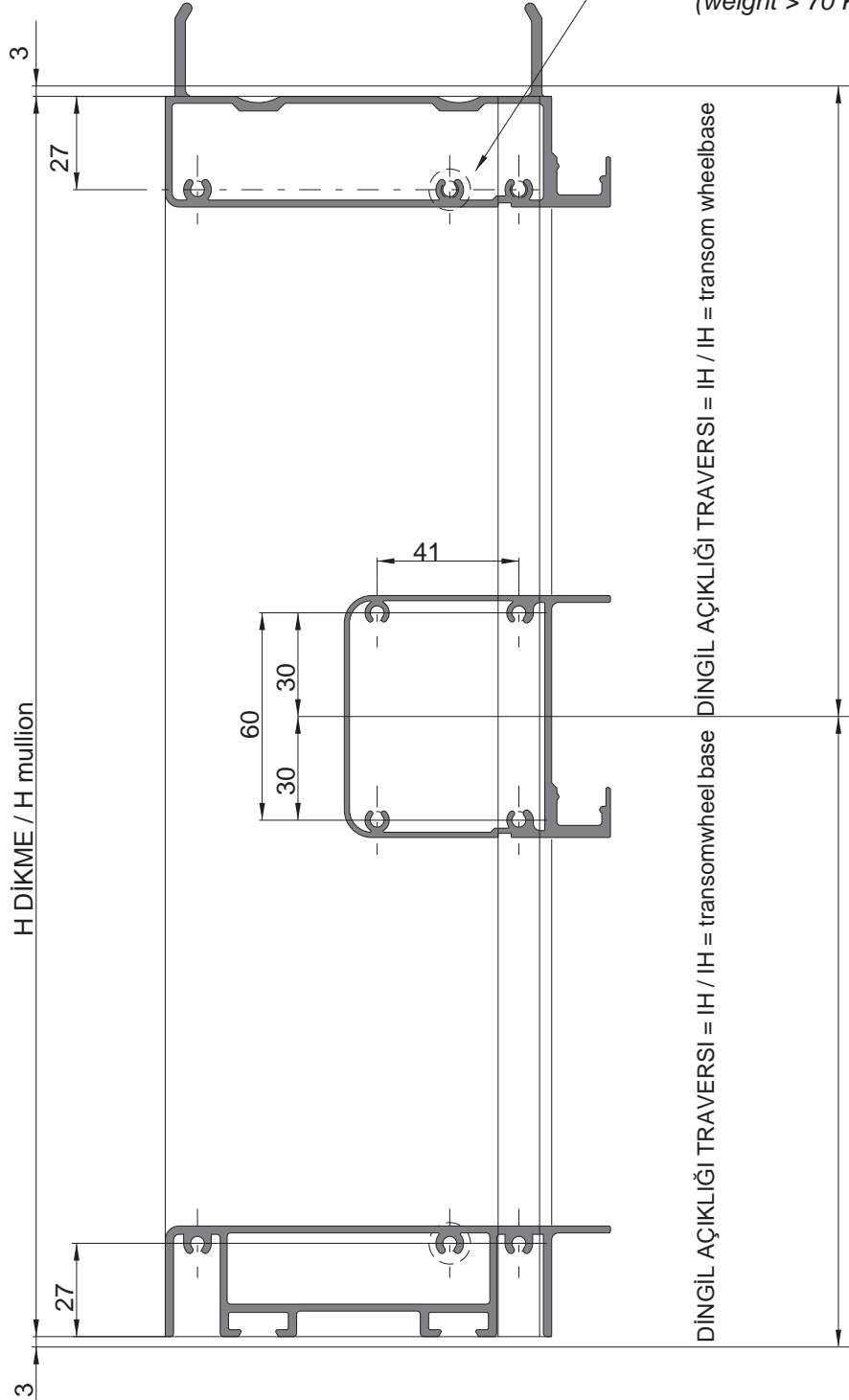

DİKME MONTAJ APARATI KOD.20.00. 200.XX
Assembling transoms on mullion code 20.00.200.XX

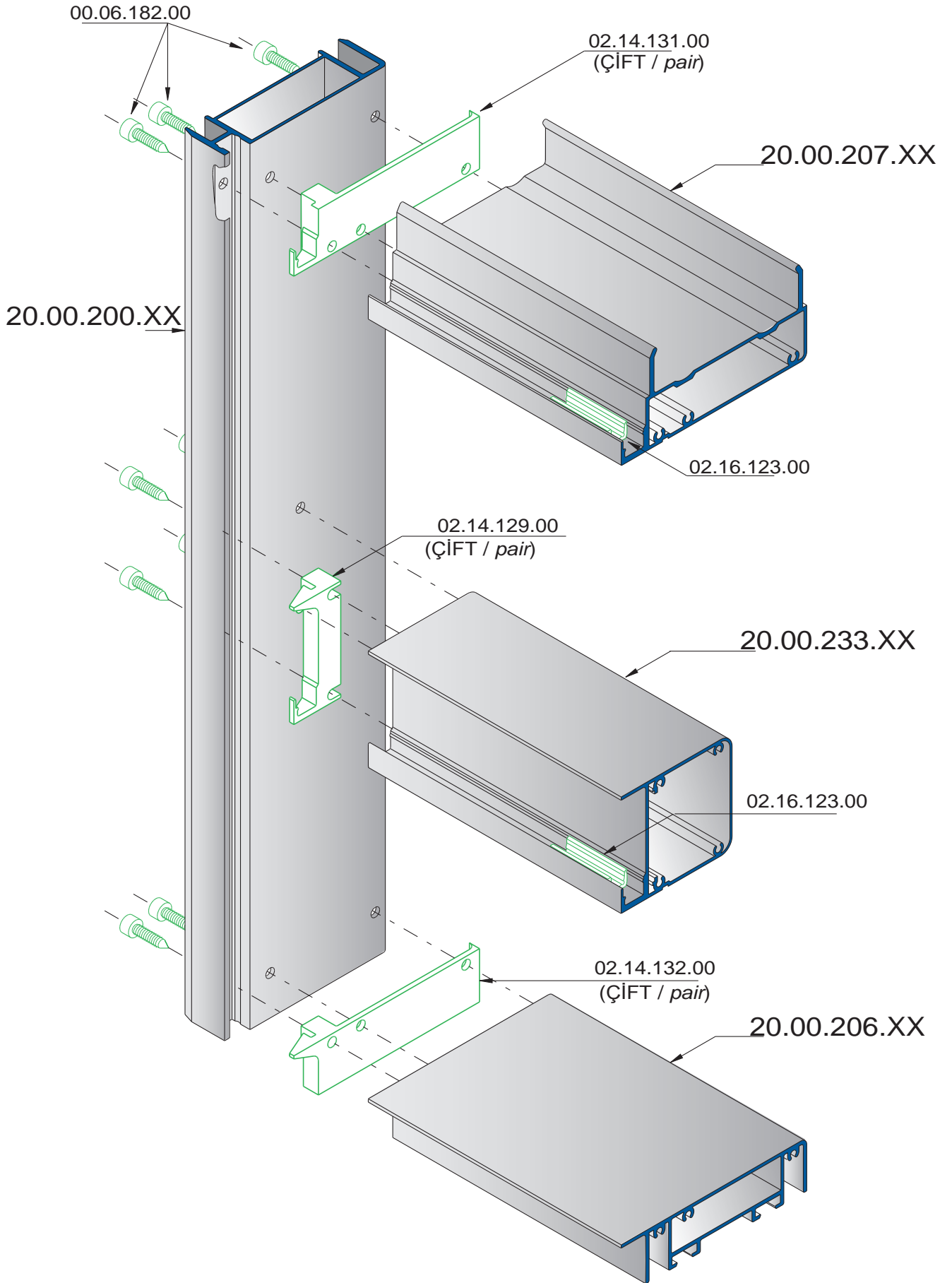

DİKME İÇİN TAKIM KOD. 20.00.283.XX
Tooling for mullion code 20.00.283.XX

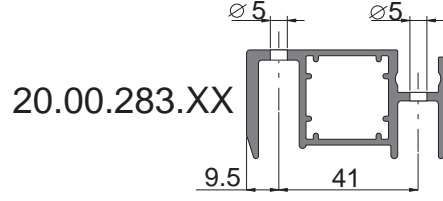

ÜST DİKME İÇİN TAKIM KOD. 20.00.292.XX
upper tooling for transom code 20.00.292.XX

ORTA DİKME İÇİN TAKIM KOD. 20.00.233.XX
middle tooling for transom code 20.00.233.XX

ALT DİKME İÇİN TAKIM KOD. 20.00.291.XX
lower tooling for transom code 20.00.291.XX

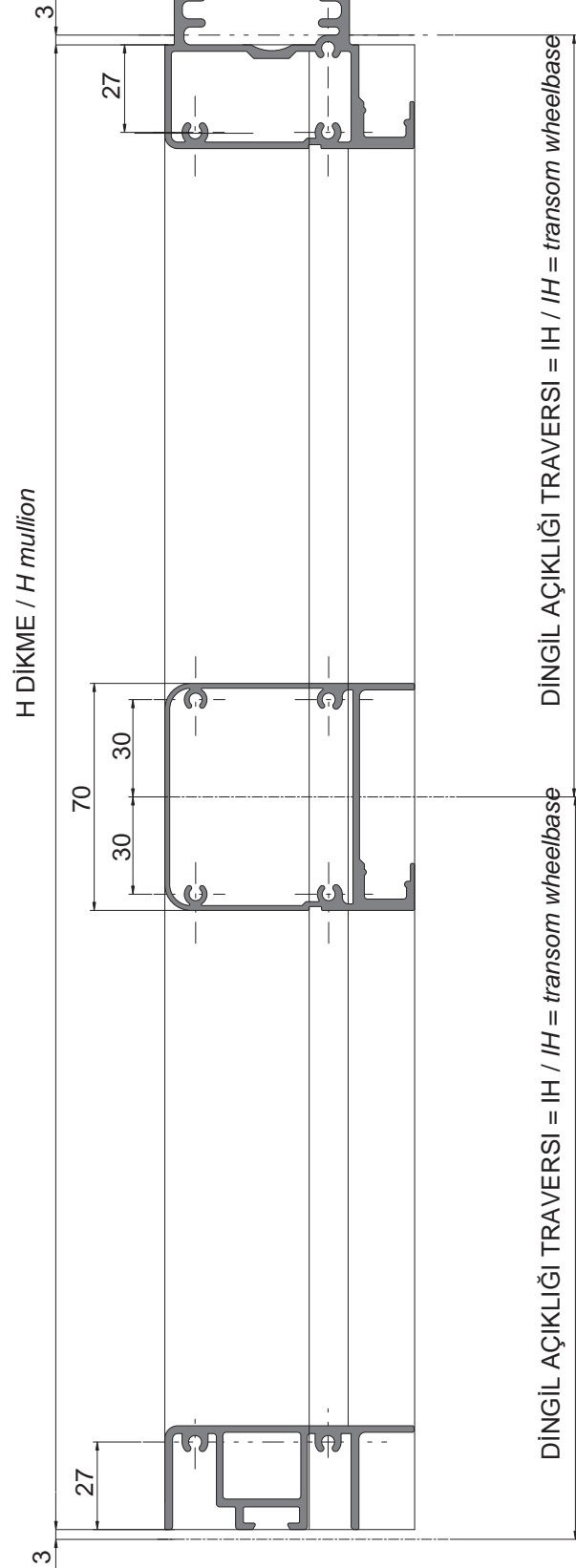

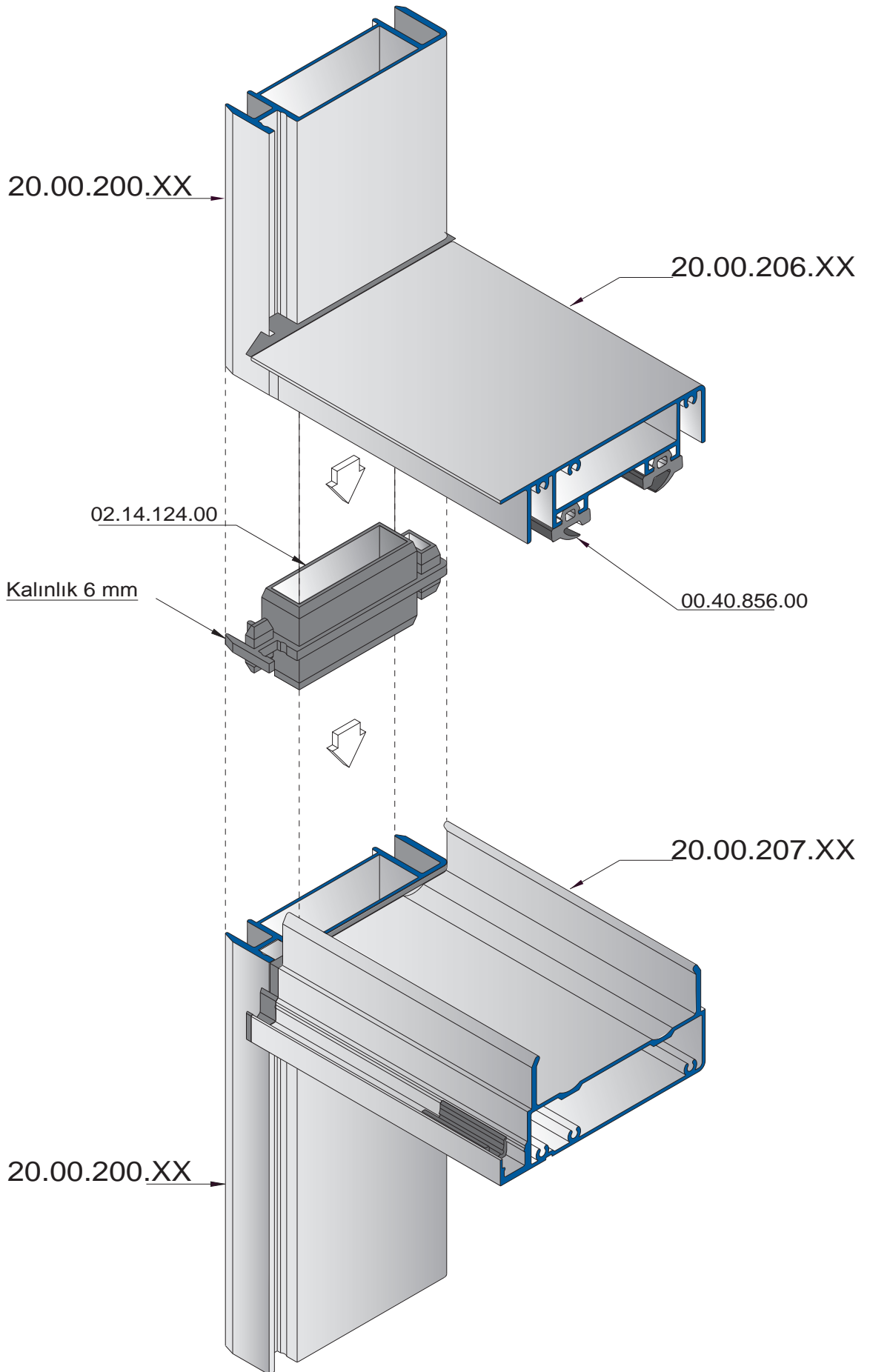

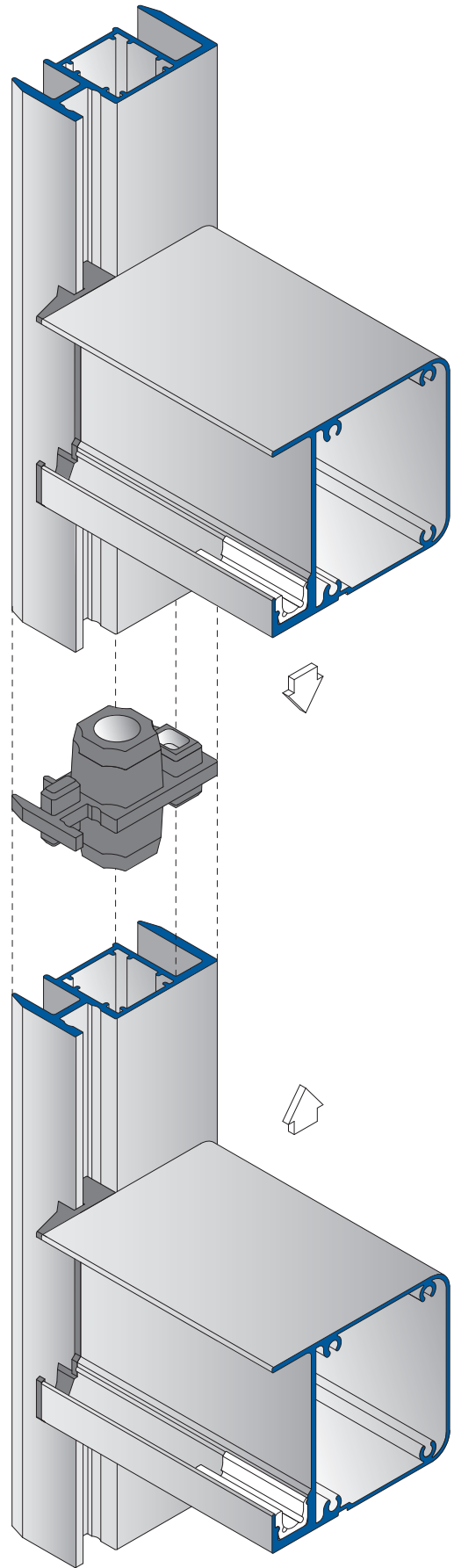
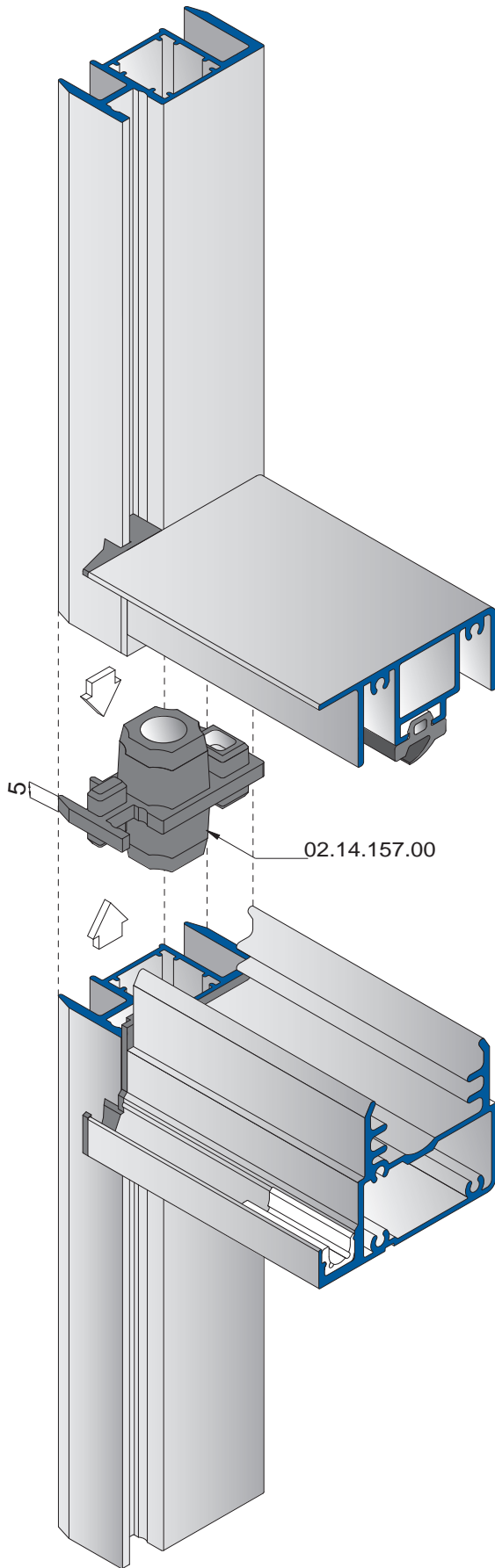

Profil Kod. 20.00.282.XX
Tooling profile code 20.00.282.XX

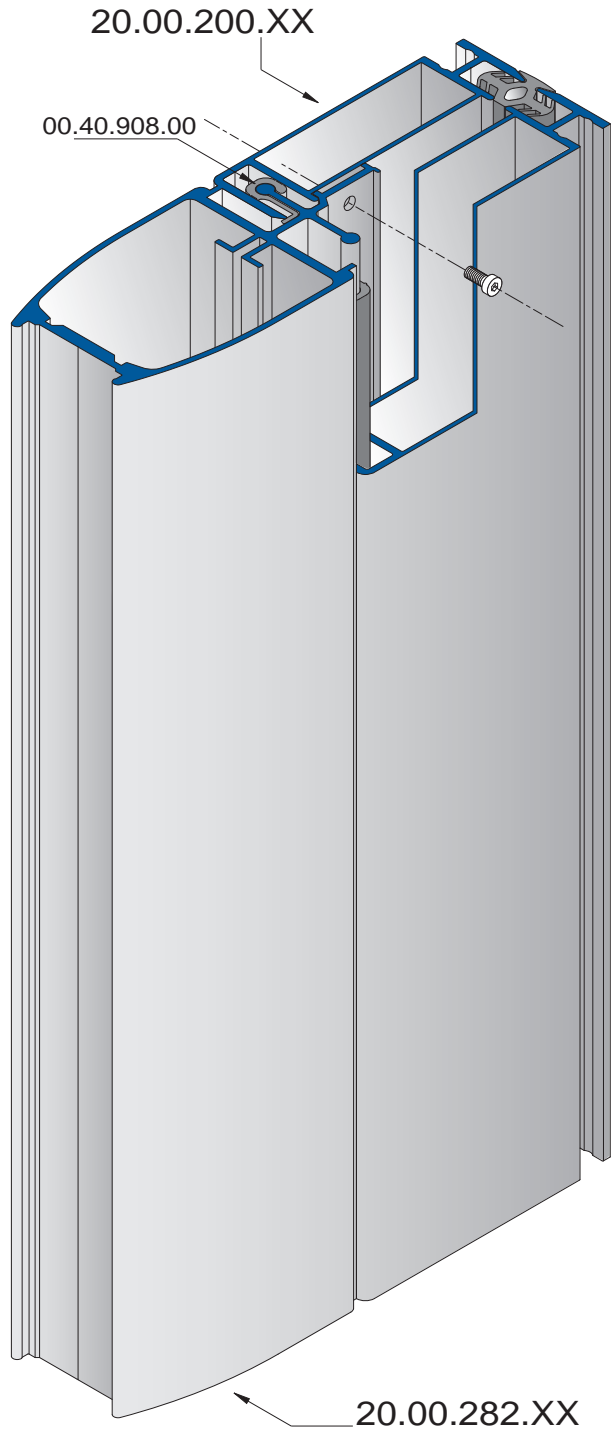
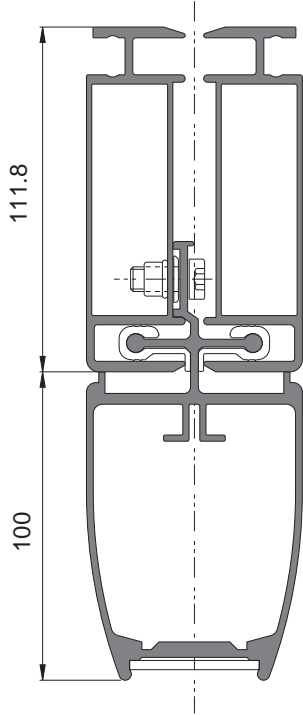

Aydınlatmayı Profile Yerleştirme Kod. 20.00.282.XX
Inserting illumination on profile code 20.00.282.XX

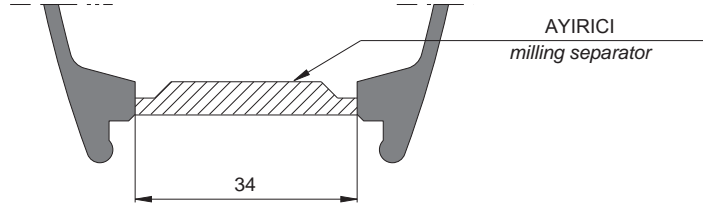
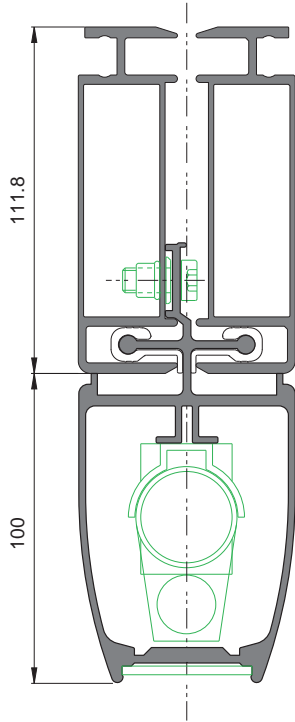

20.00.200.XX



ÜST PLASTİK KAPAK KOD
(00.41.912.00)

finishing plastic translucent profile
(00.41.912.00)

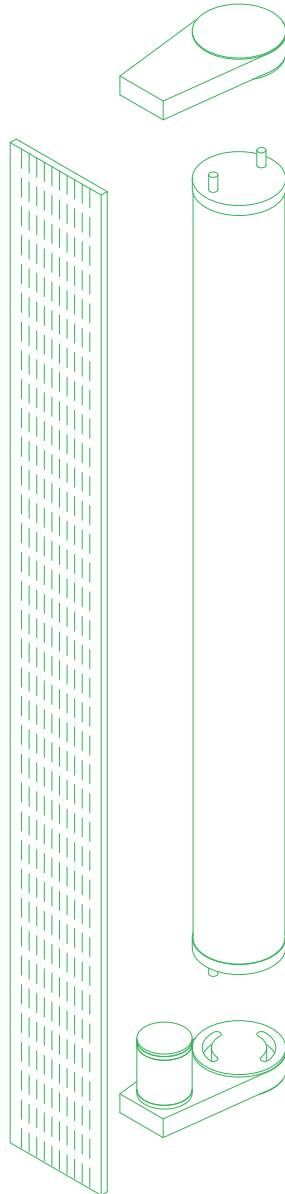

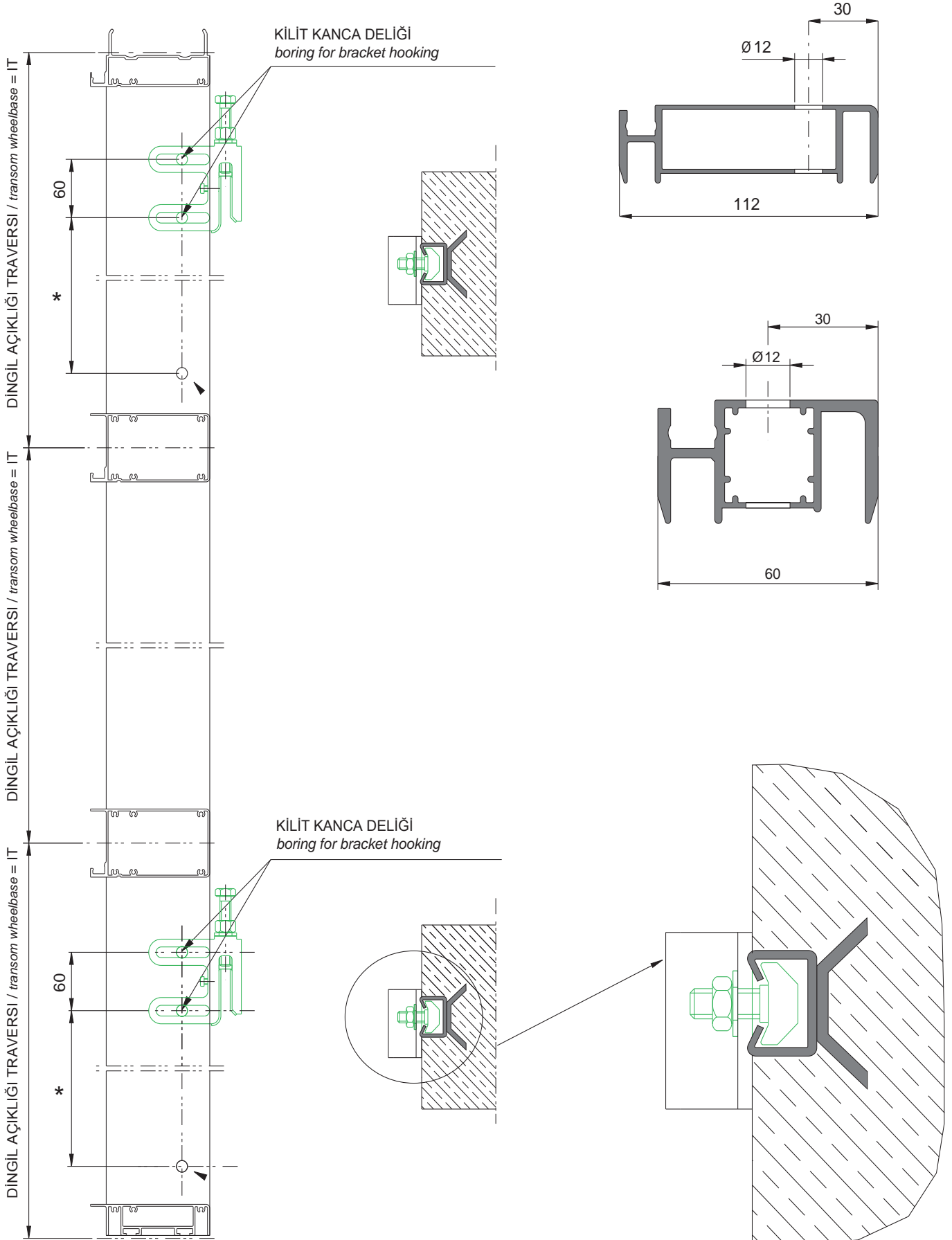

ANKOR KOD. 02.24.139.00
Anchoring code 02.24.139.00

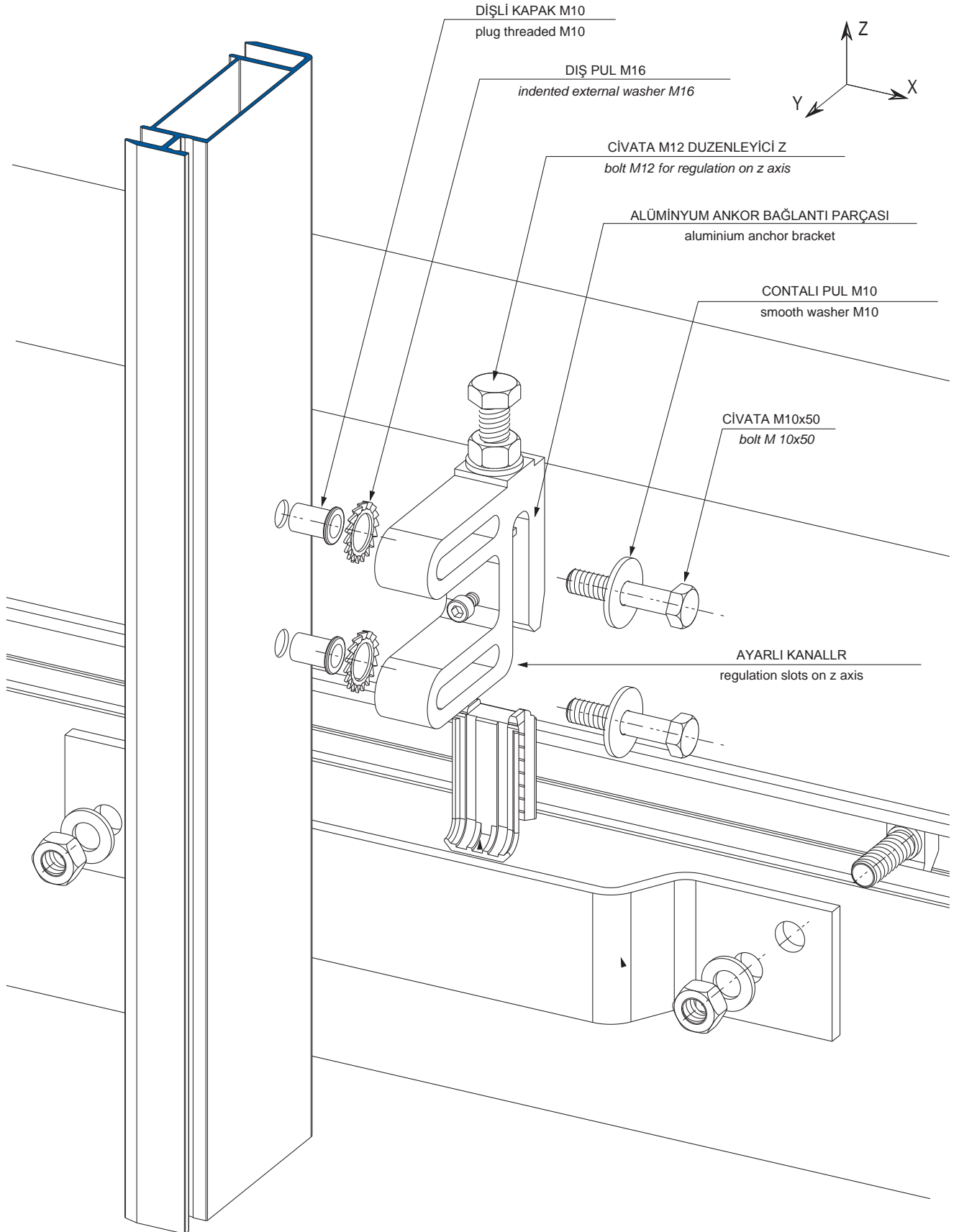

ANKOR KOD. 02.24.139.00 PROFİL KOD. 20.00.200.XX
 Anchoring code 02.24.139.00 on profile code 20.00.200.XX

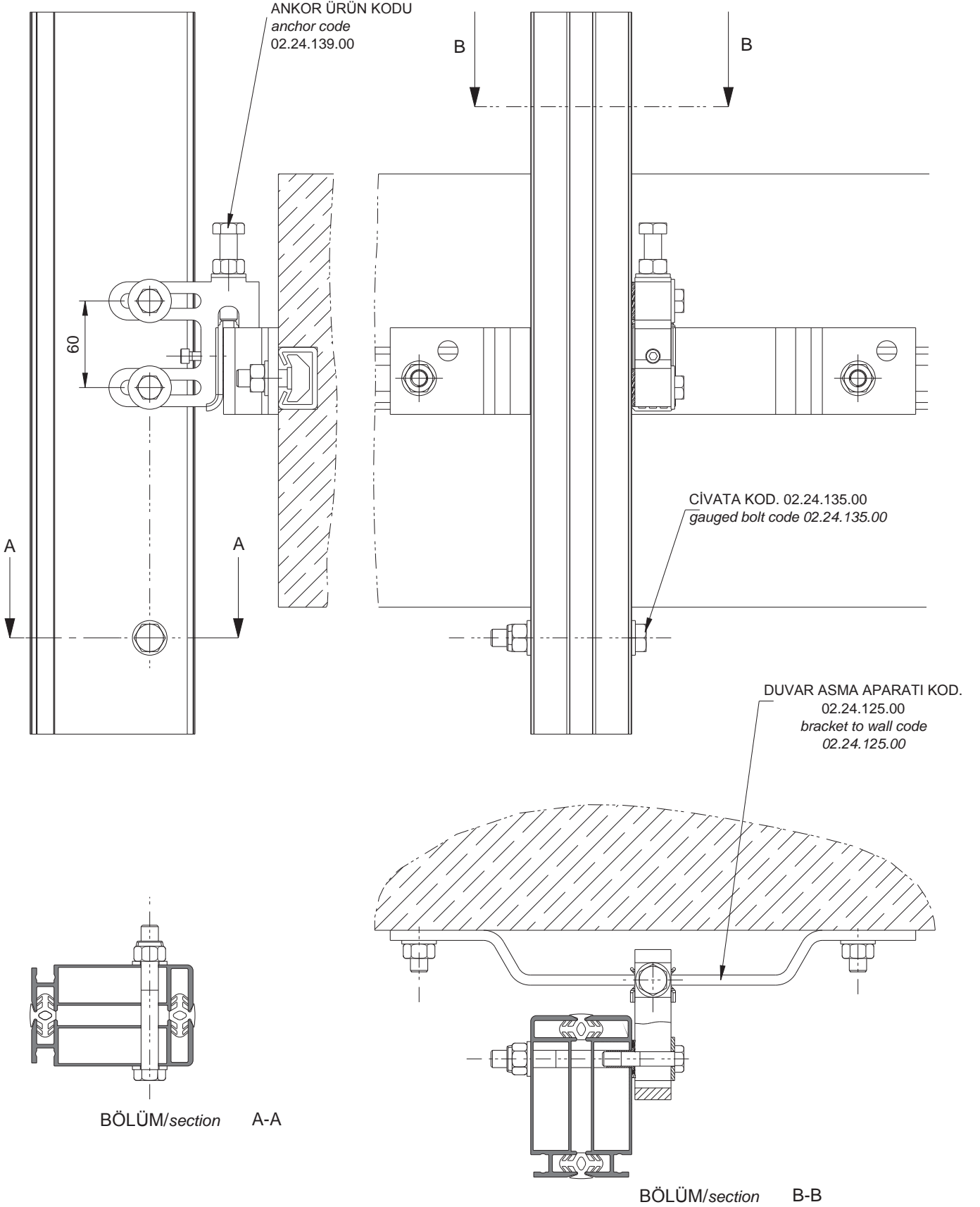

ANKOR KOD. 02.24.139.00 PROFİL 20.00.283.XX
Anchoring 02.24.139.00 on profile 20.00.283.XX

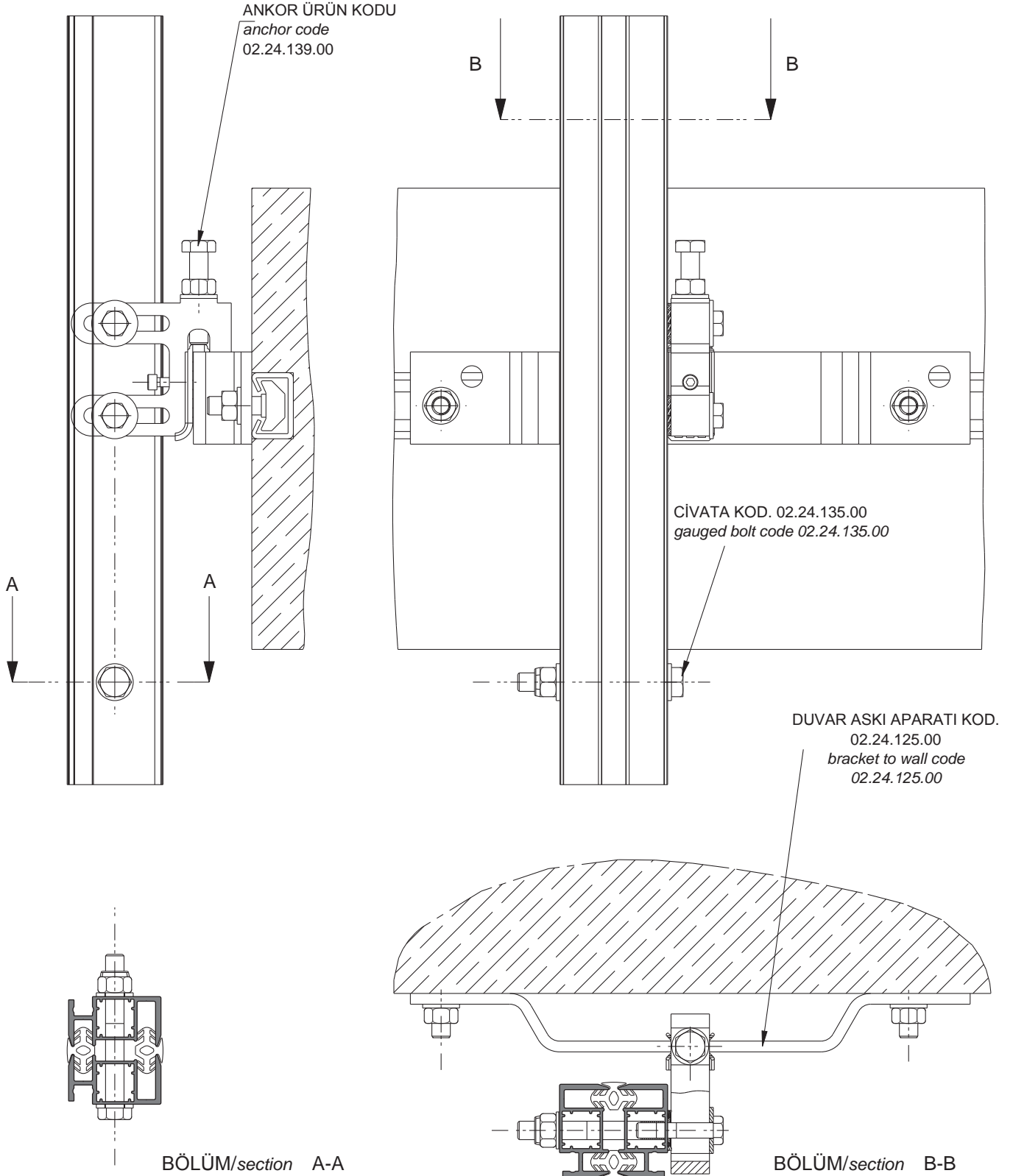

ANKOR DİZAYN
Anchoring cells on attic

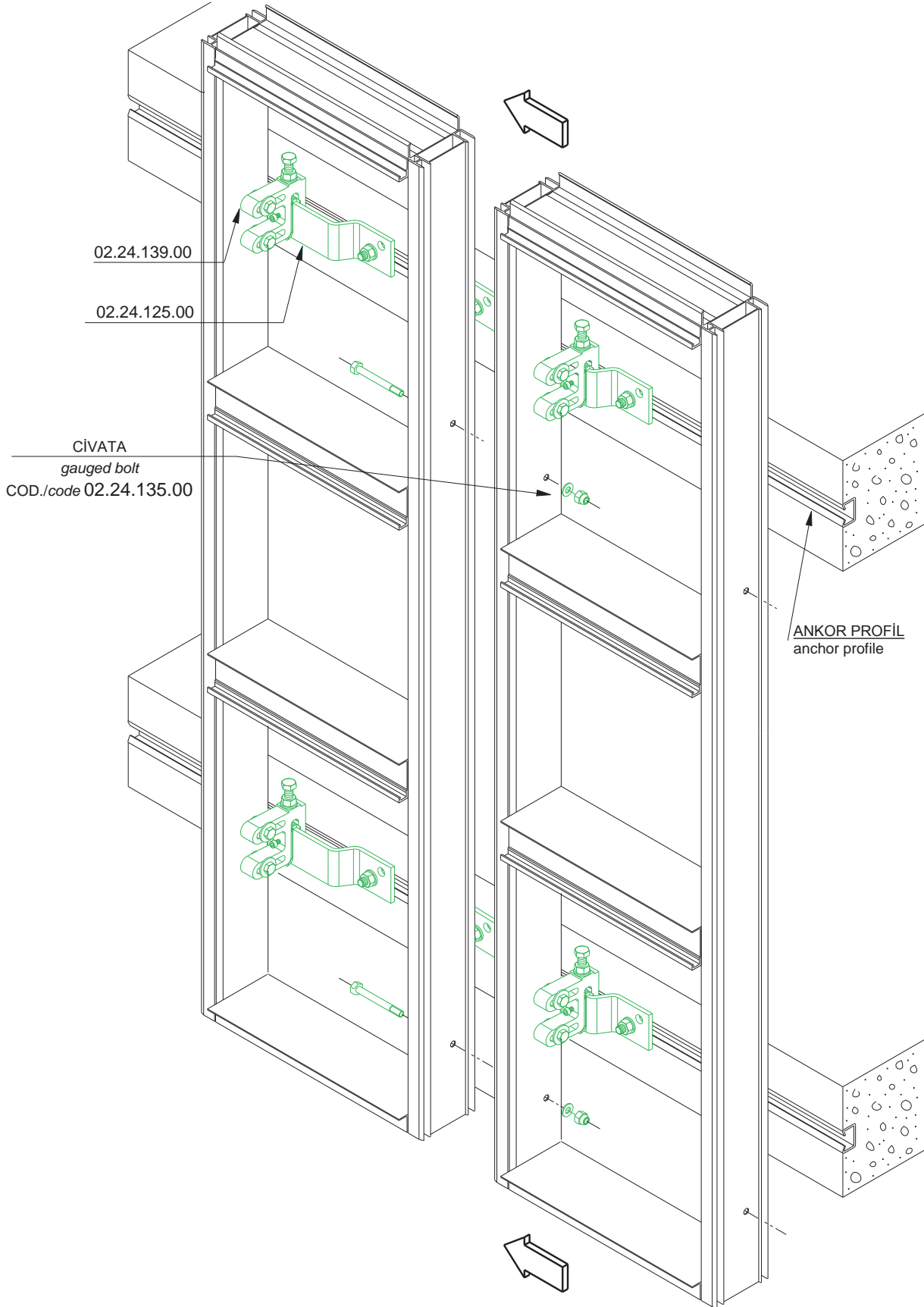

ANKOR DİZAYN
Anchoring cells on attic

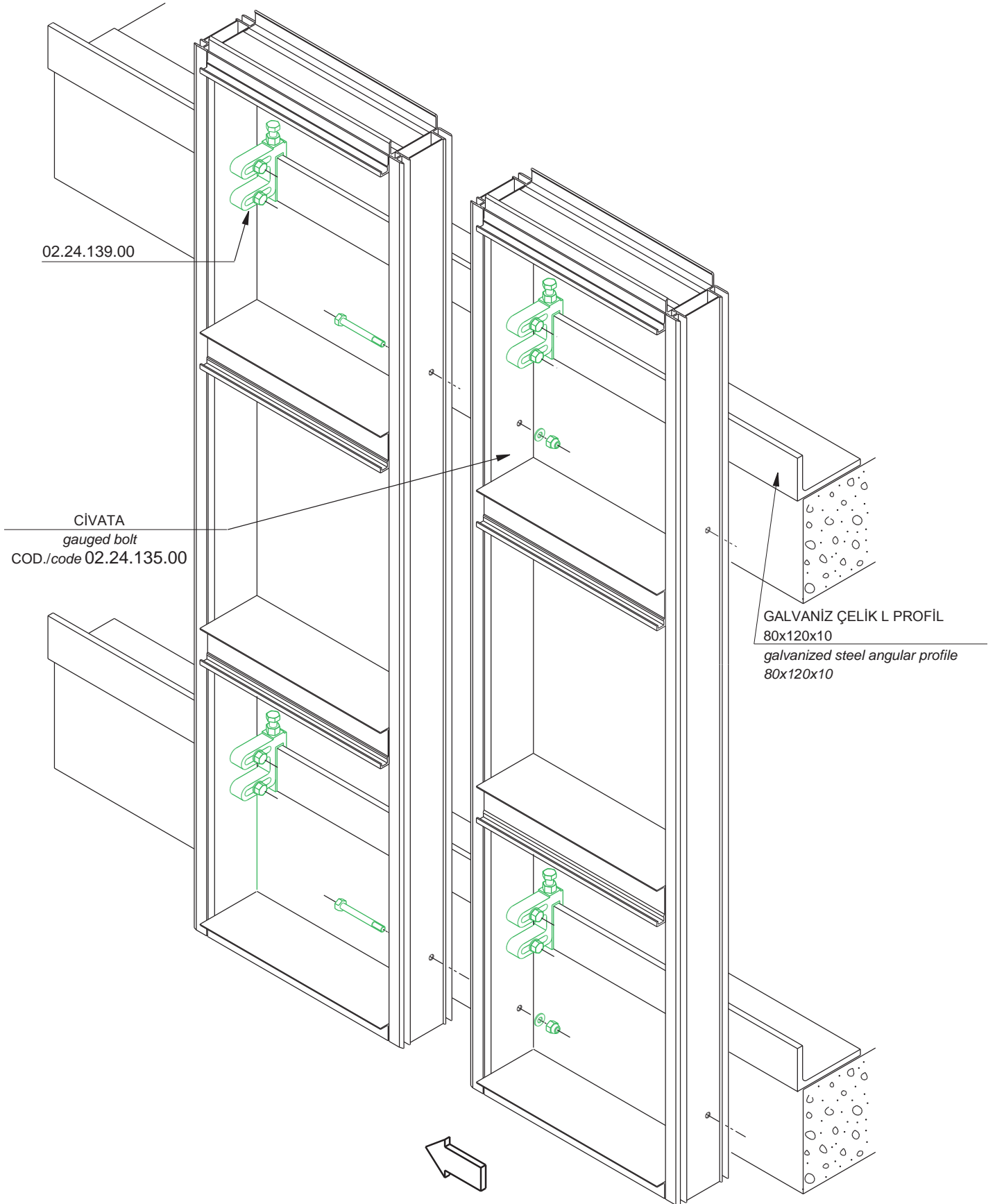

ANKOR HÜCRE KOD. 20.00.283.XX

Anchoring cells on attic on mullion code 20.00.283.XX

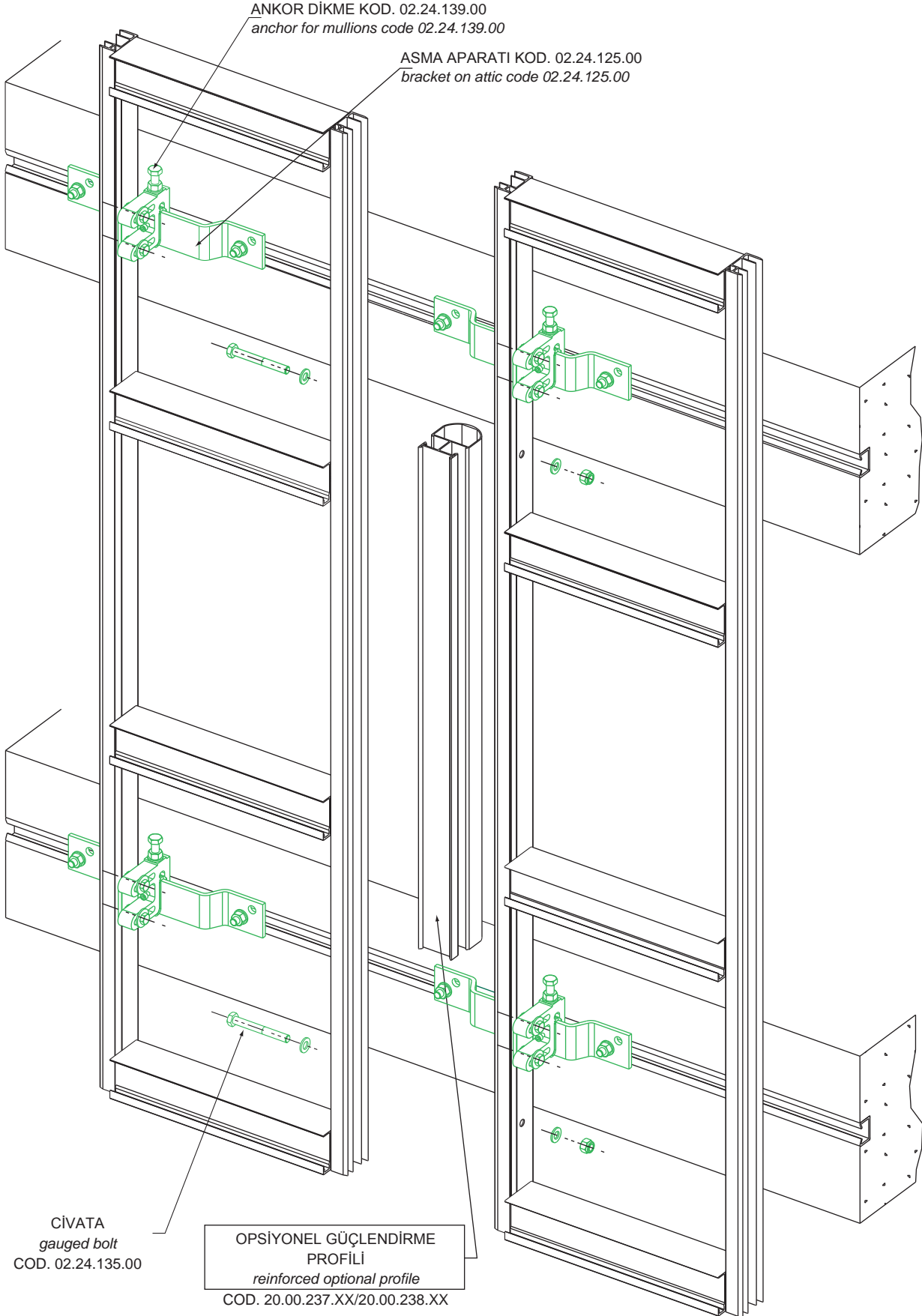

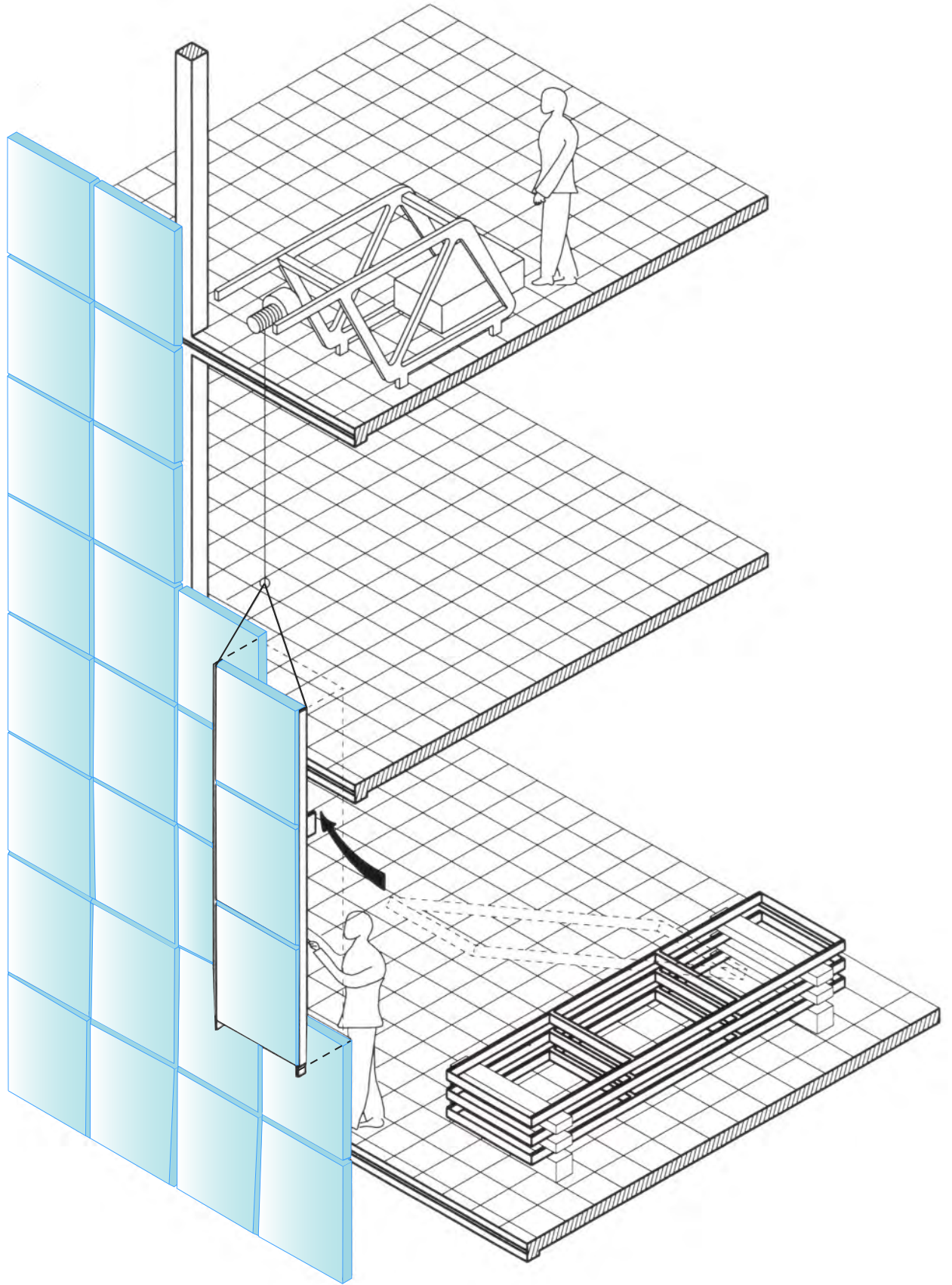

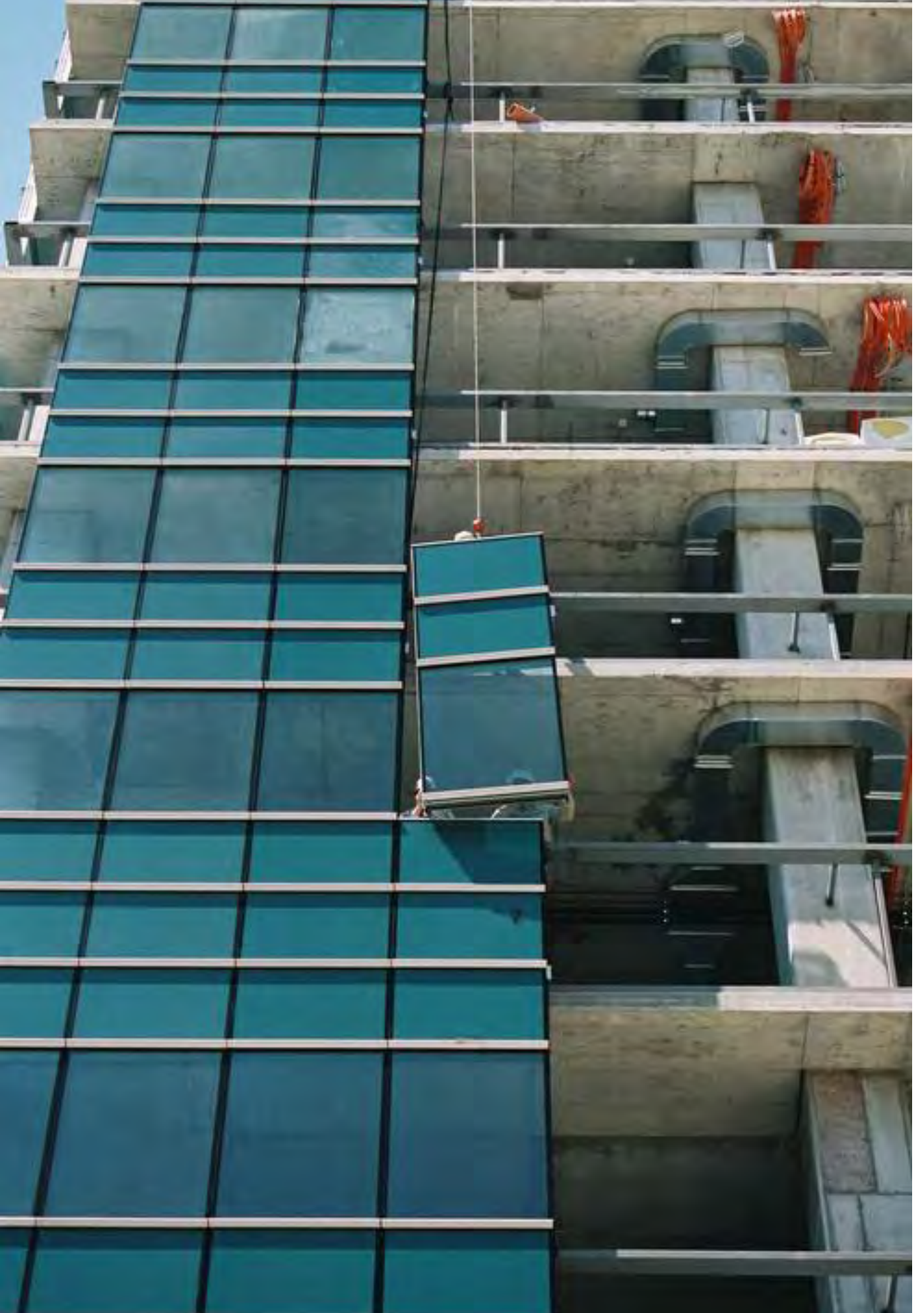



Duvara Monteleme Fixing to Wall

REFERANS BÖLÜMLERİ Sections reference

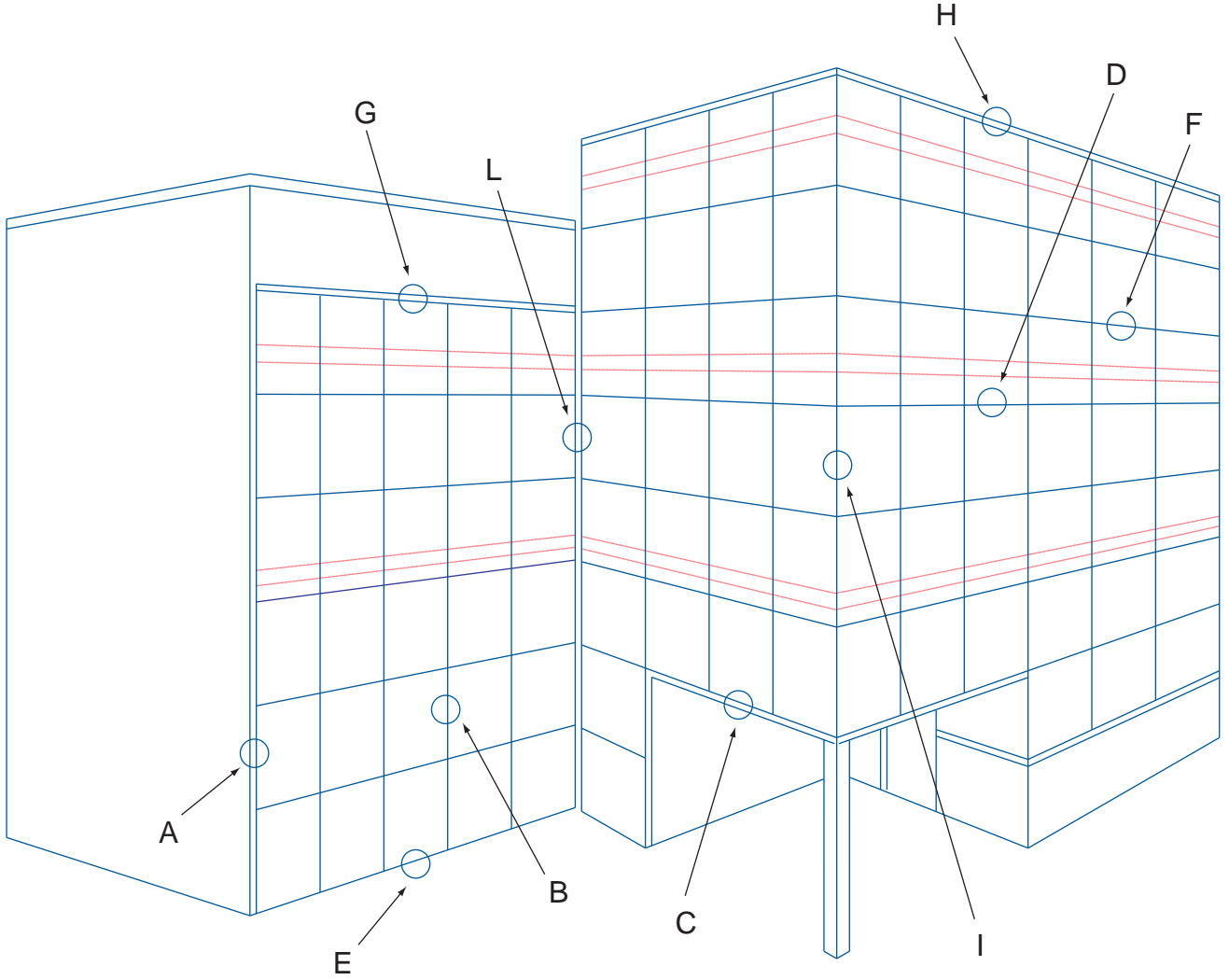

Takip eden sayfalarda rapor edilen bölümler gösterge niteliğindedir, termal kesintili yarı yapısal cephe için bir örnektir (MKAV Kod. 22.00.210.XX).

Sections reported on following pages are indicative, are an example for a thermal break semistructural façade (wing code 22.00.210.XX).

Yan Levha bölüm Lateral section with plates

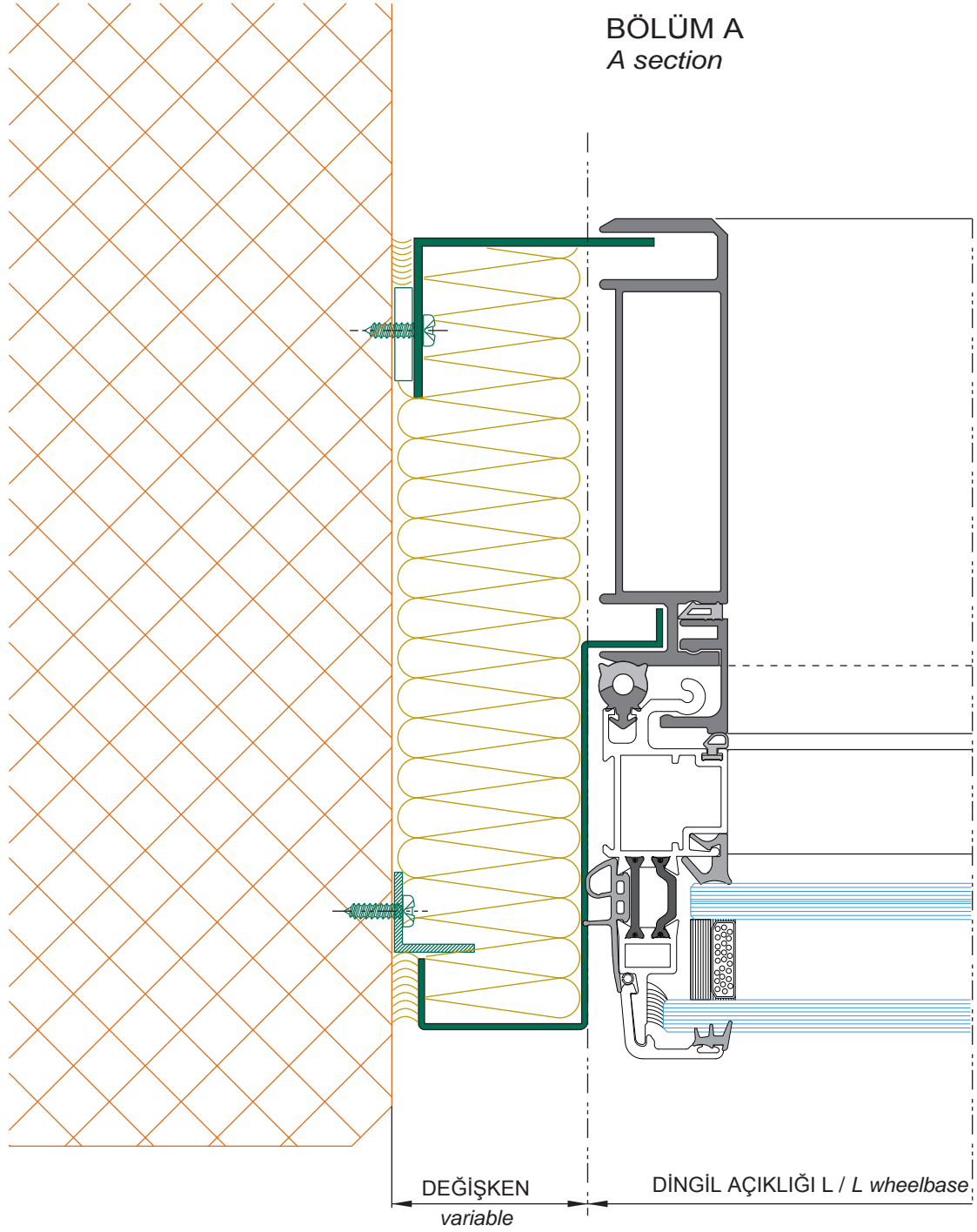

ORTA BÖLÜM
Middle section

BÖLÜM B
B section

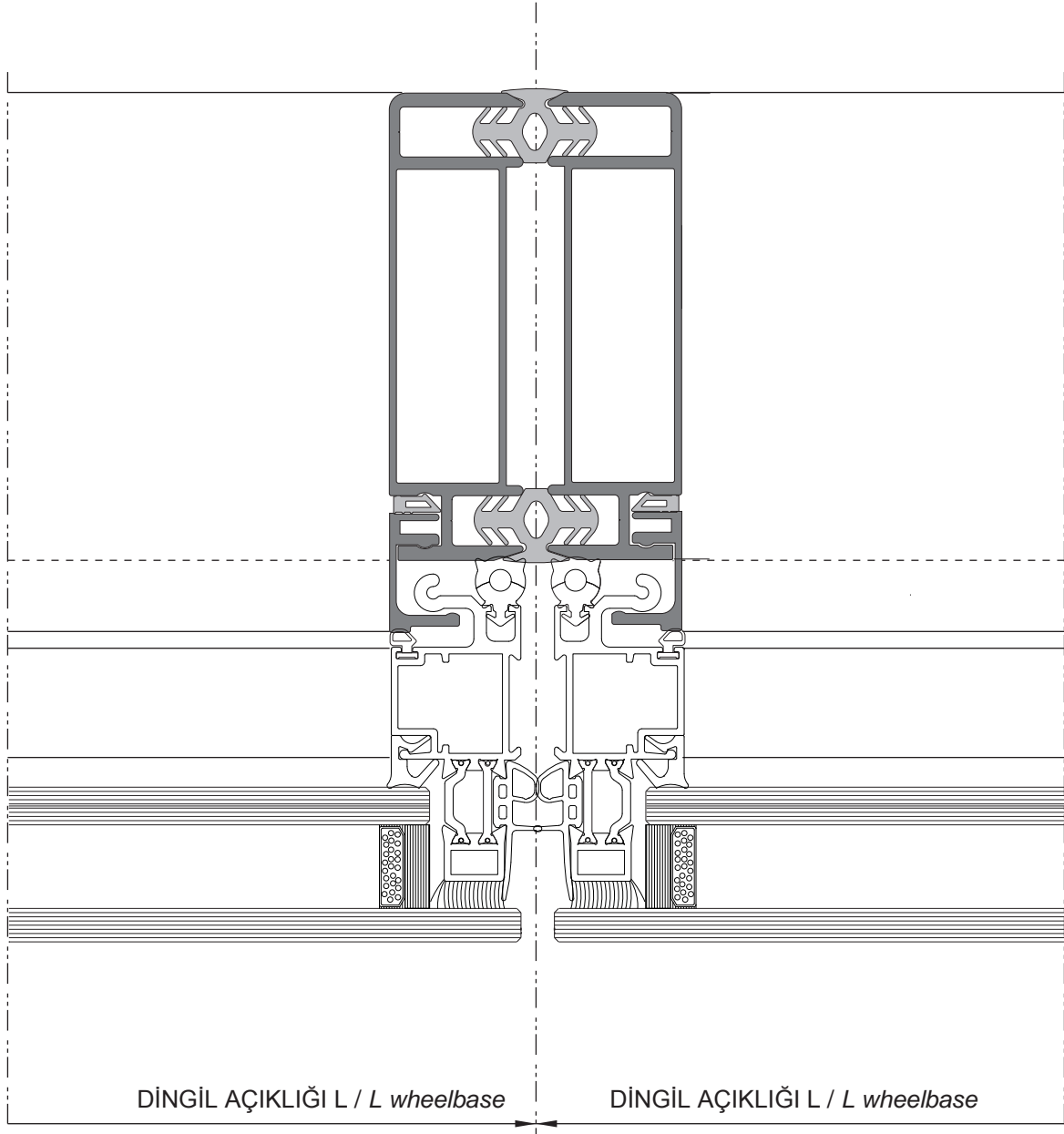

ALT TABAN BAĞLANTI
Lower floor connection section

BÖLÜM C
C section

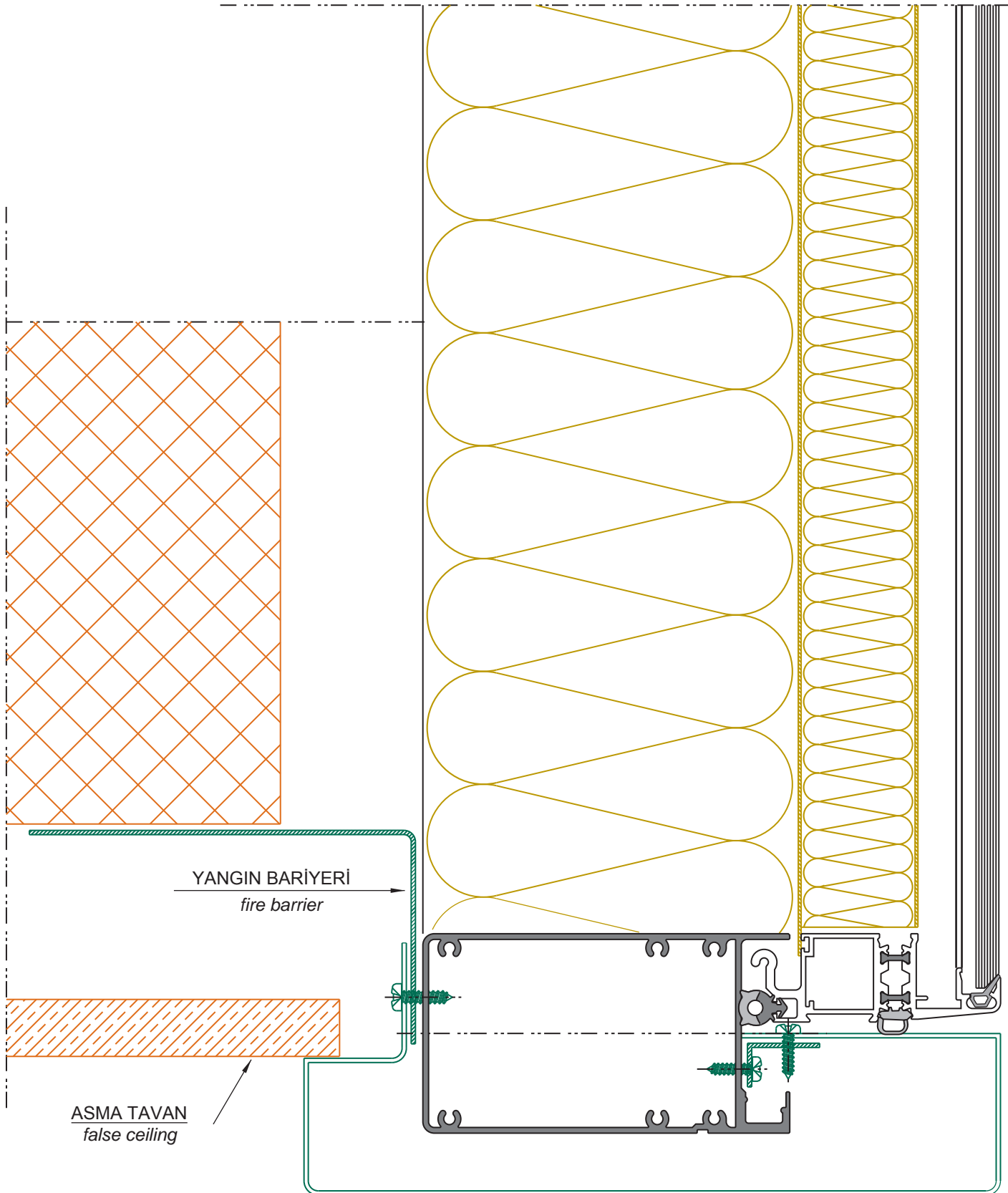

ALT TABAN BAĞLANTI
Floor connection section

BÖLÜM D
D section

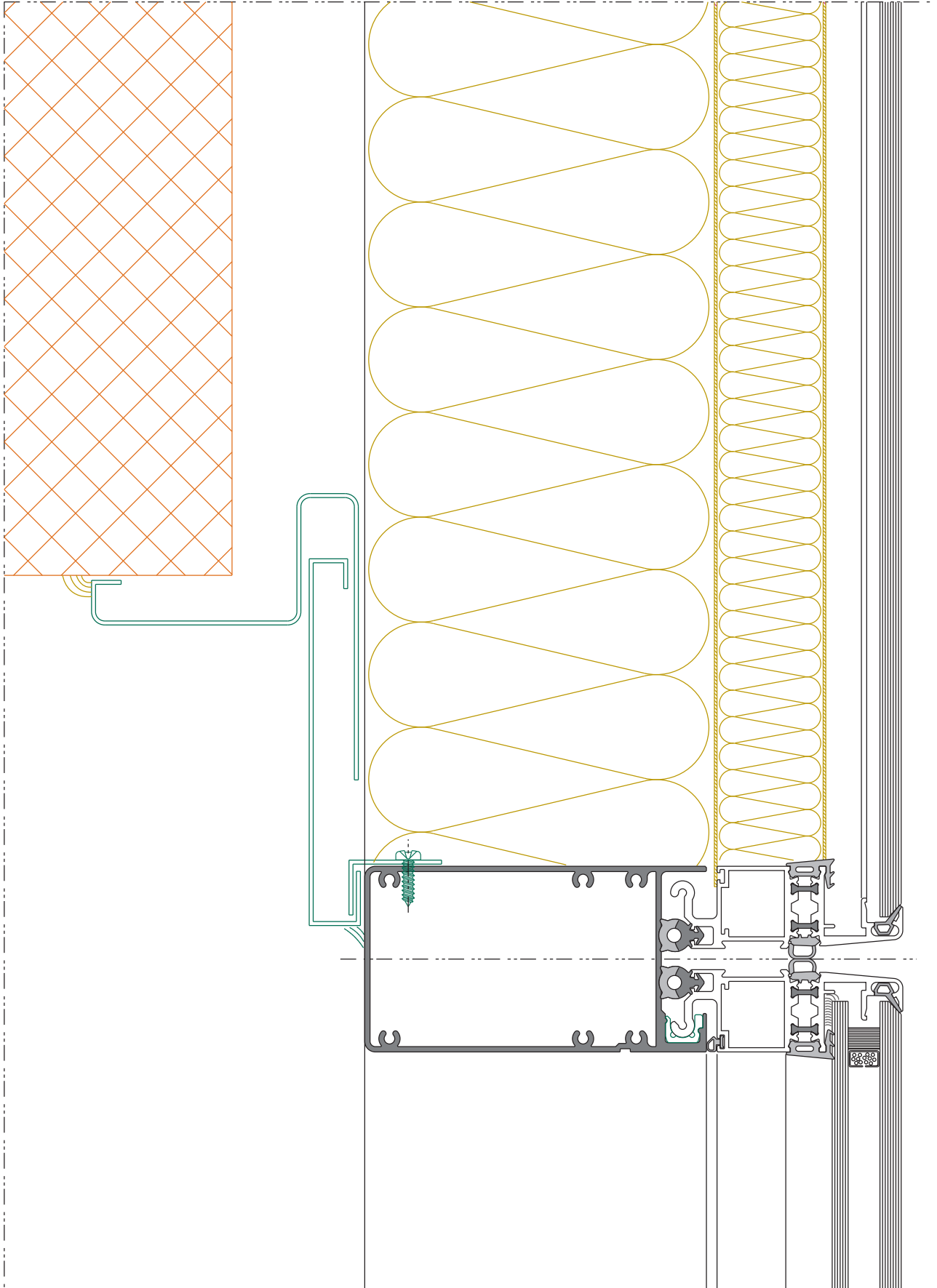

ASMA TAVAN BÖLÜMÜ (VARYANT)
False ceiling section (variant)

BÖLÜMD
D section

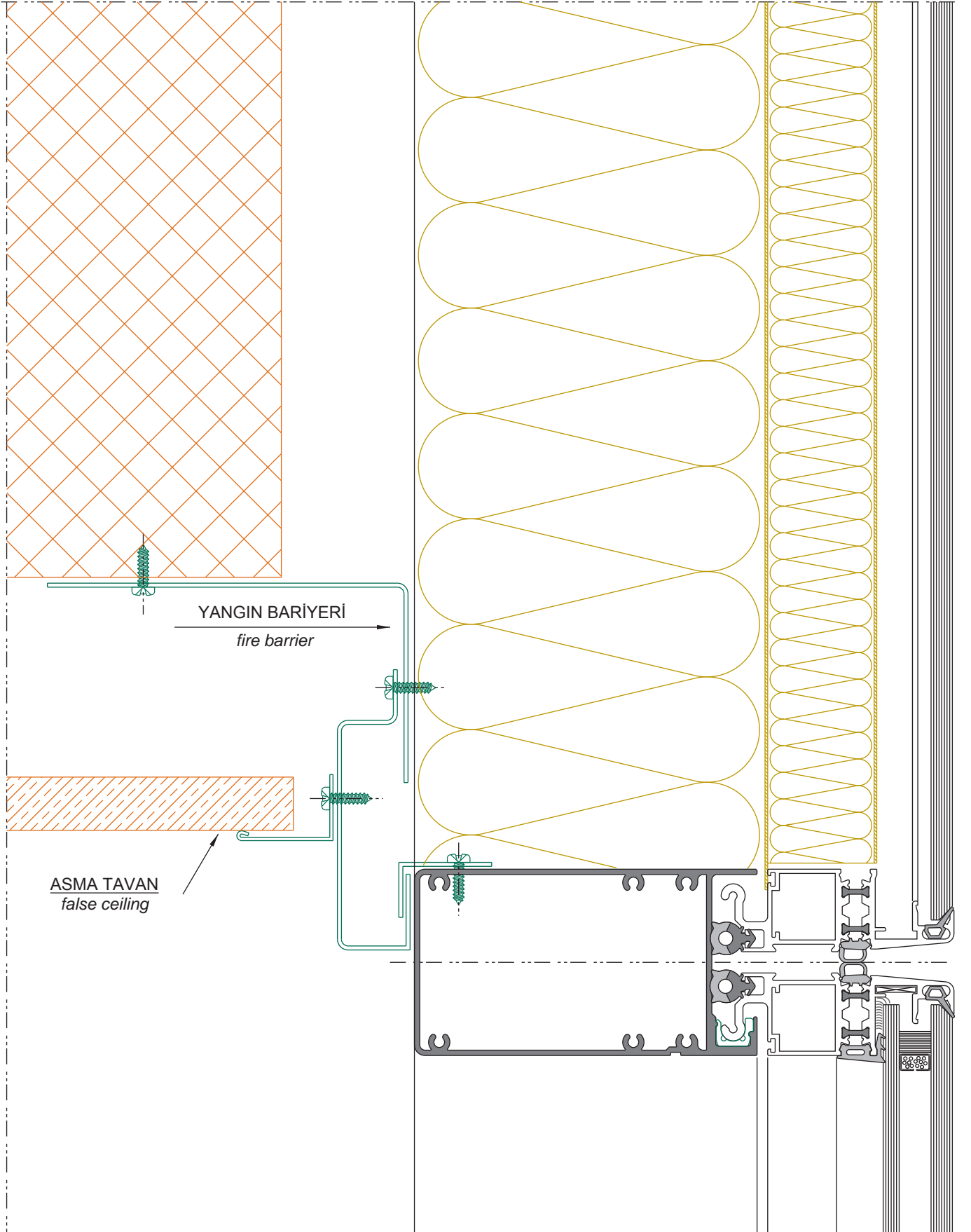

BÖLÜM E
E section

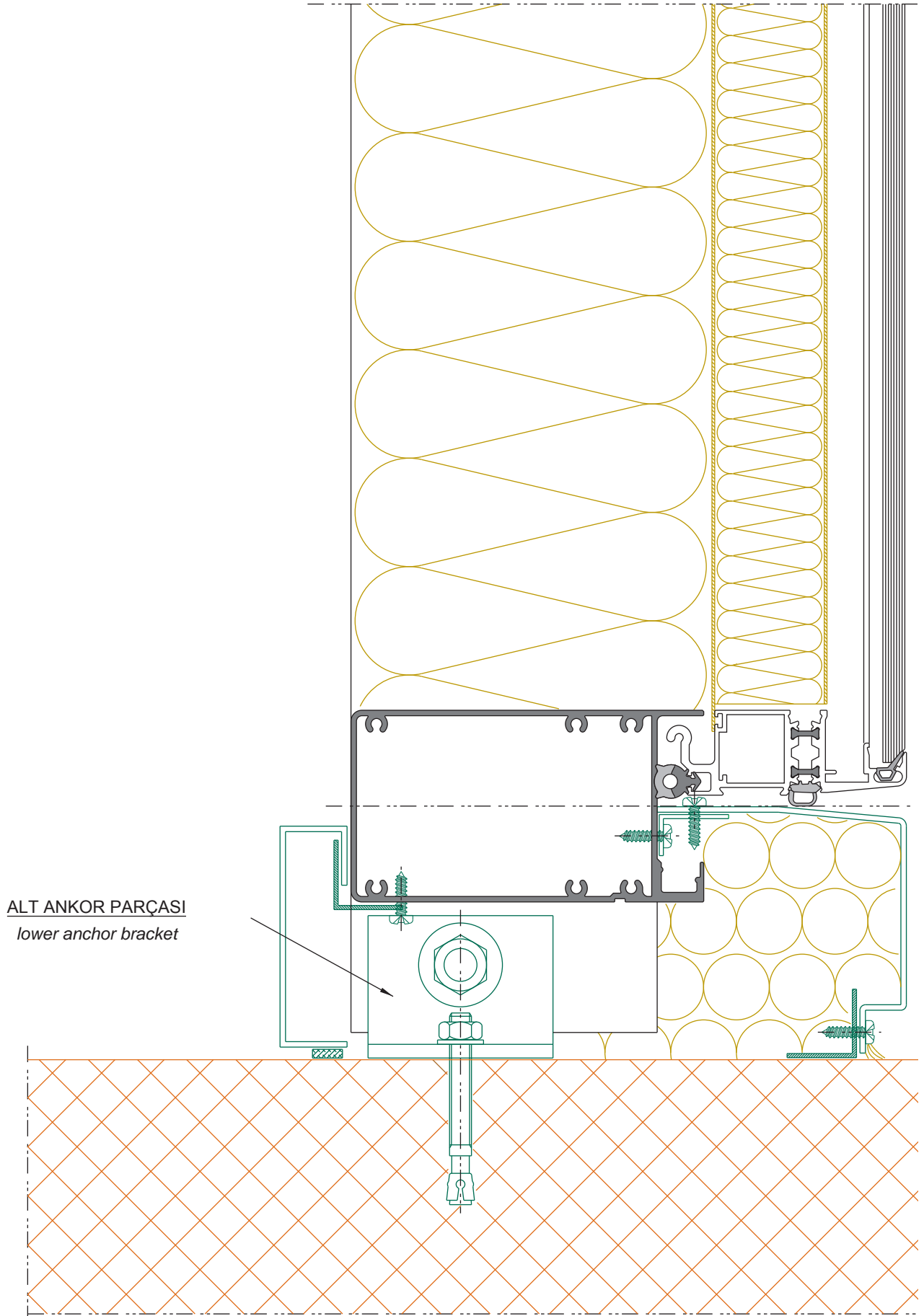

ALT ANKOR PARÇASI
lower anchor bracket

BÖLÜM F
F section

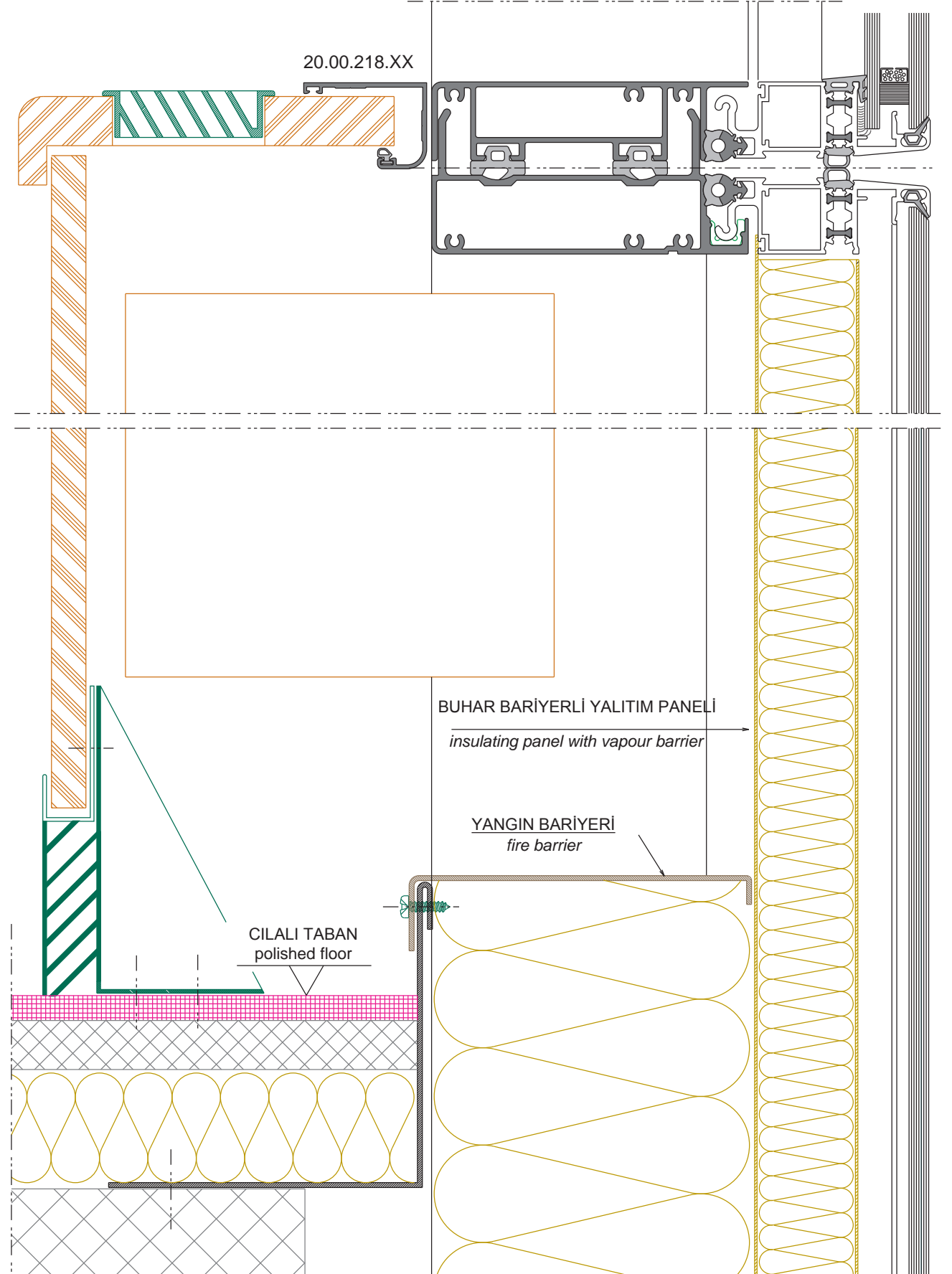

BÖLÜM F (VARYANT)
F section (variant)

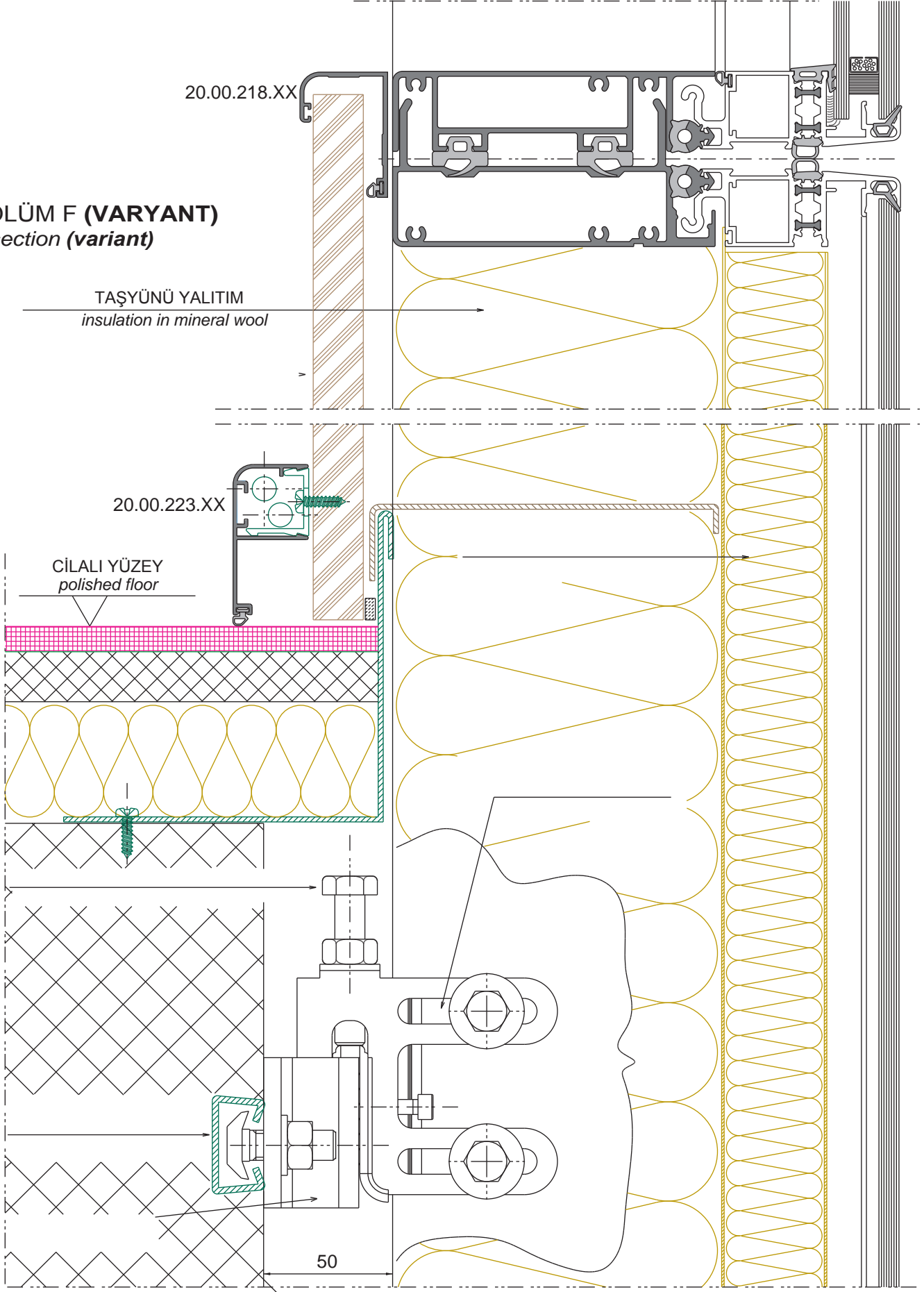

BÖLÜM G
G section

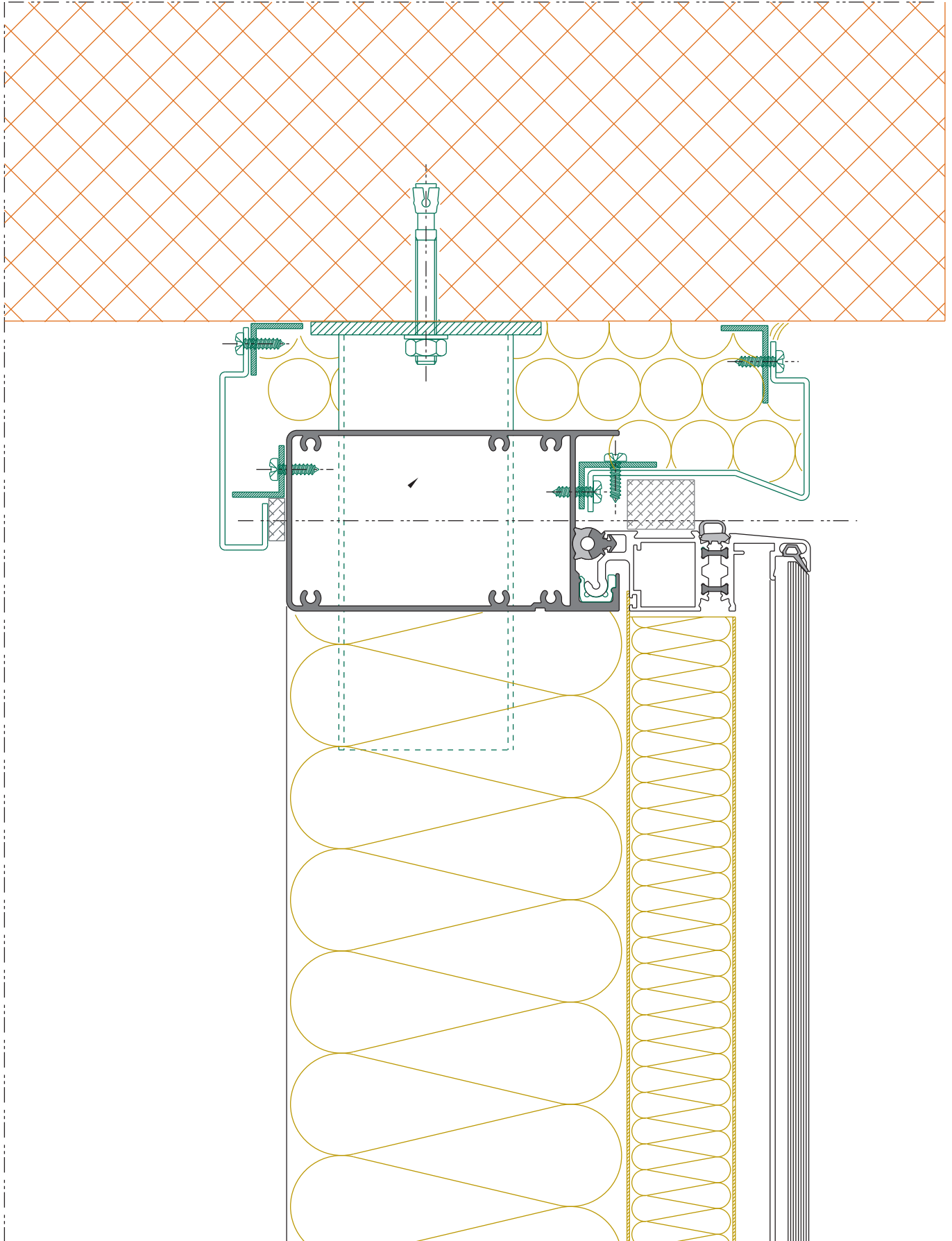

BÖLÜM H
H section

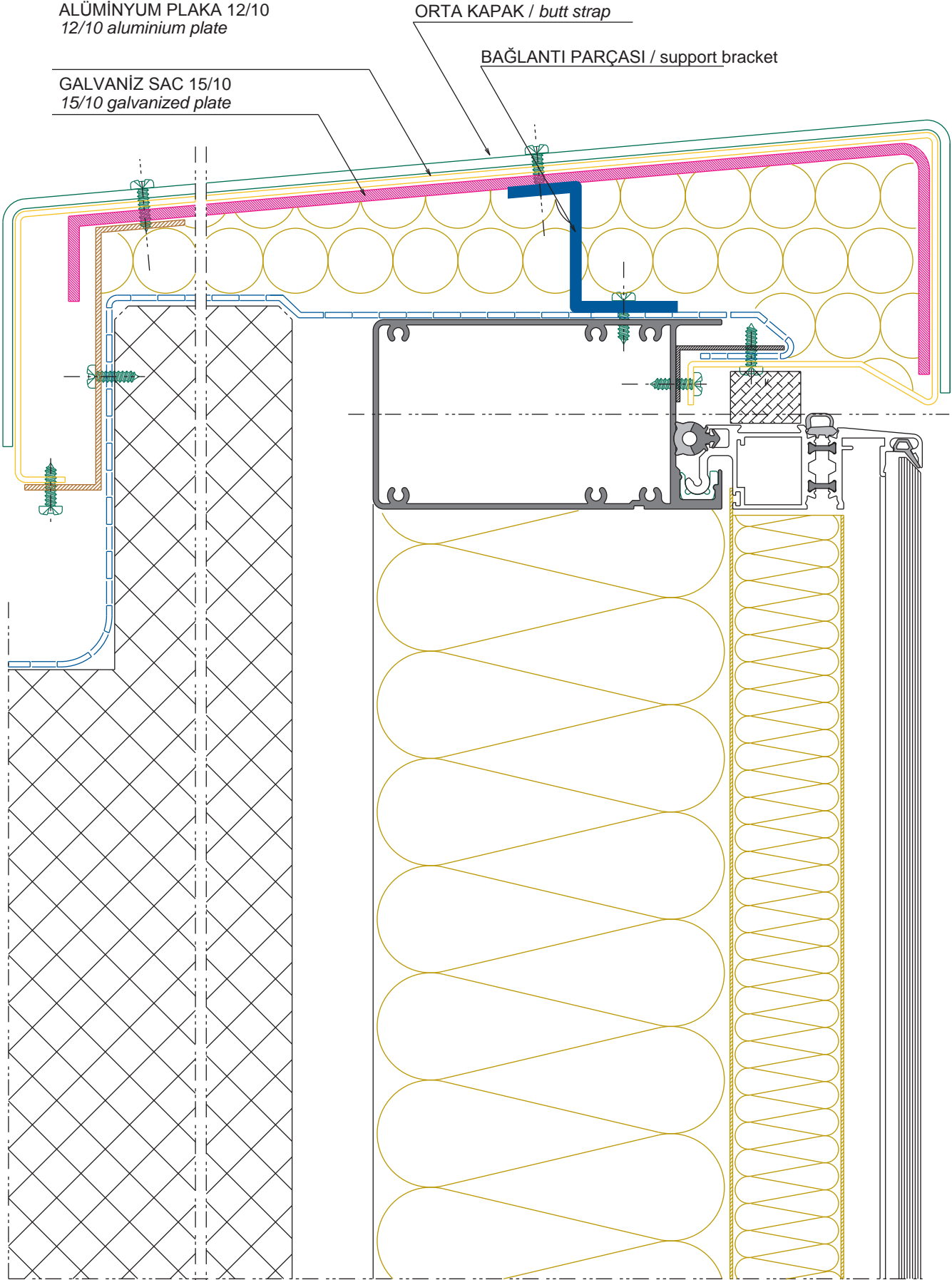

AÇILI DİKEY KANAT
Positive angle for horizontal wings

BÖLÜM (VARYANT)
section (variant)

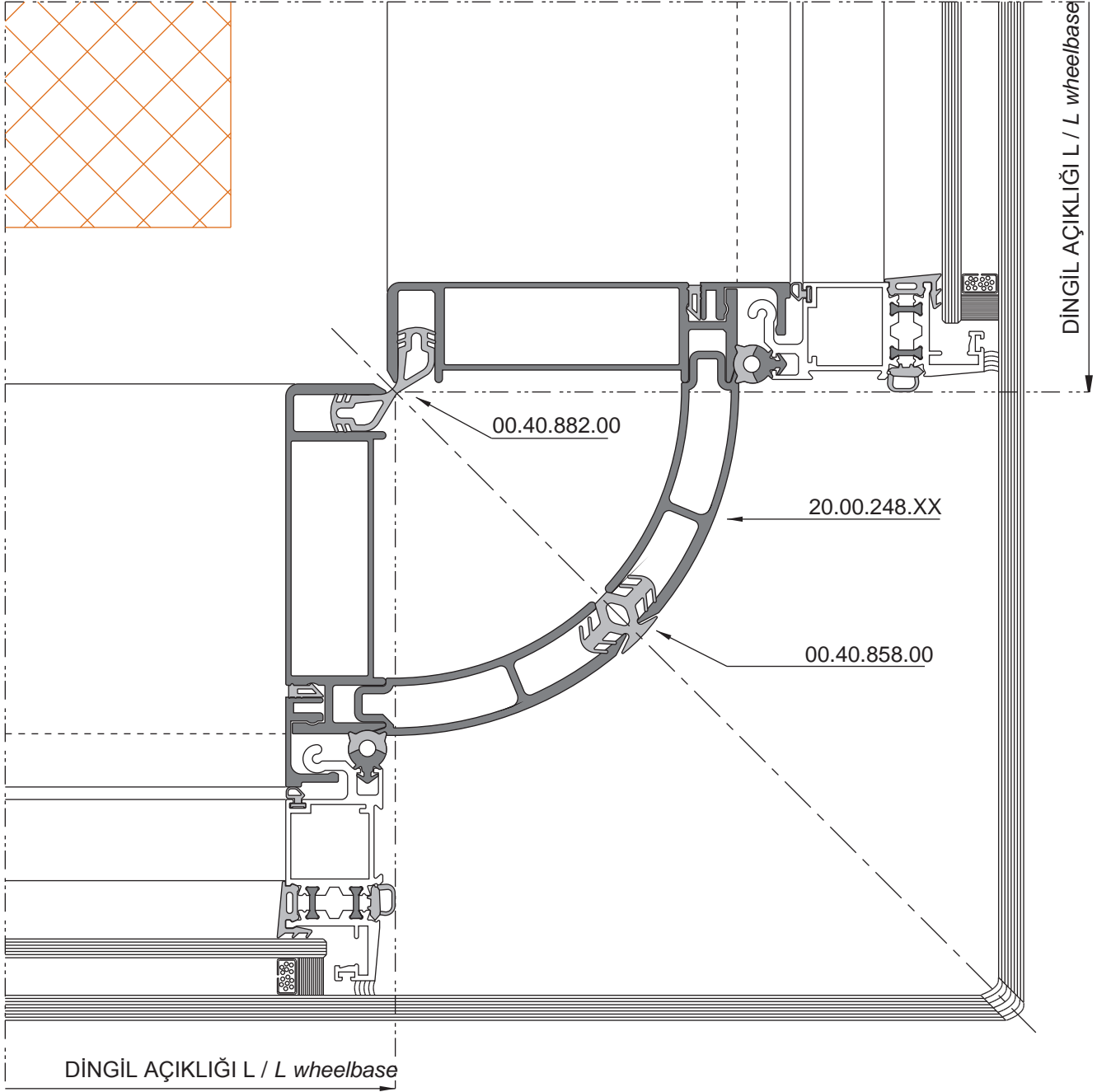

TERS AÇI
negative angle

BÖLÜM L
L section

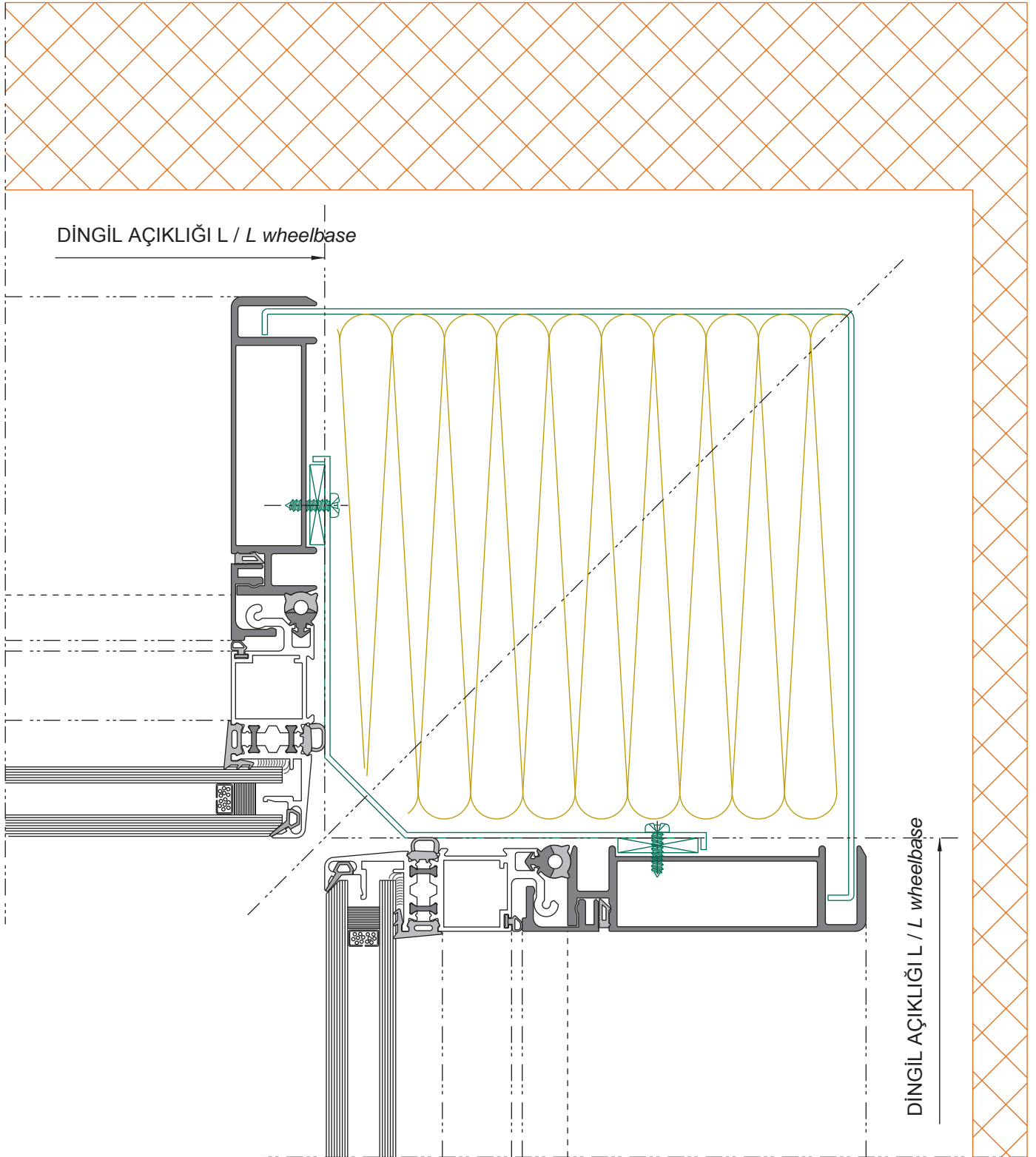

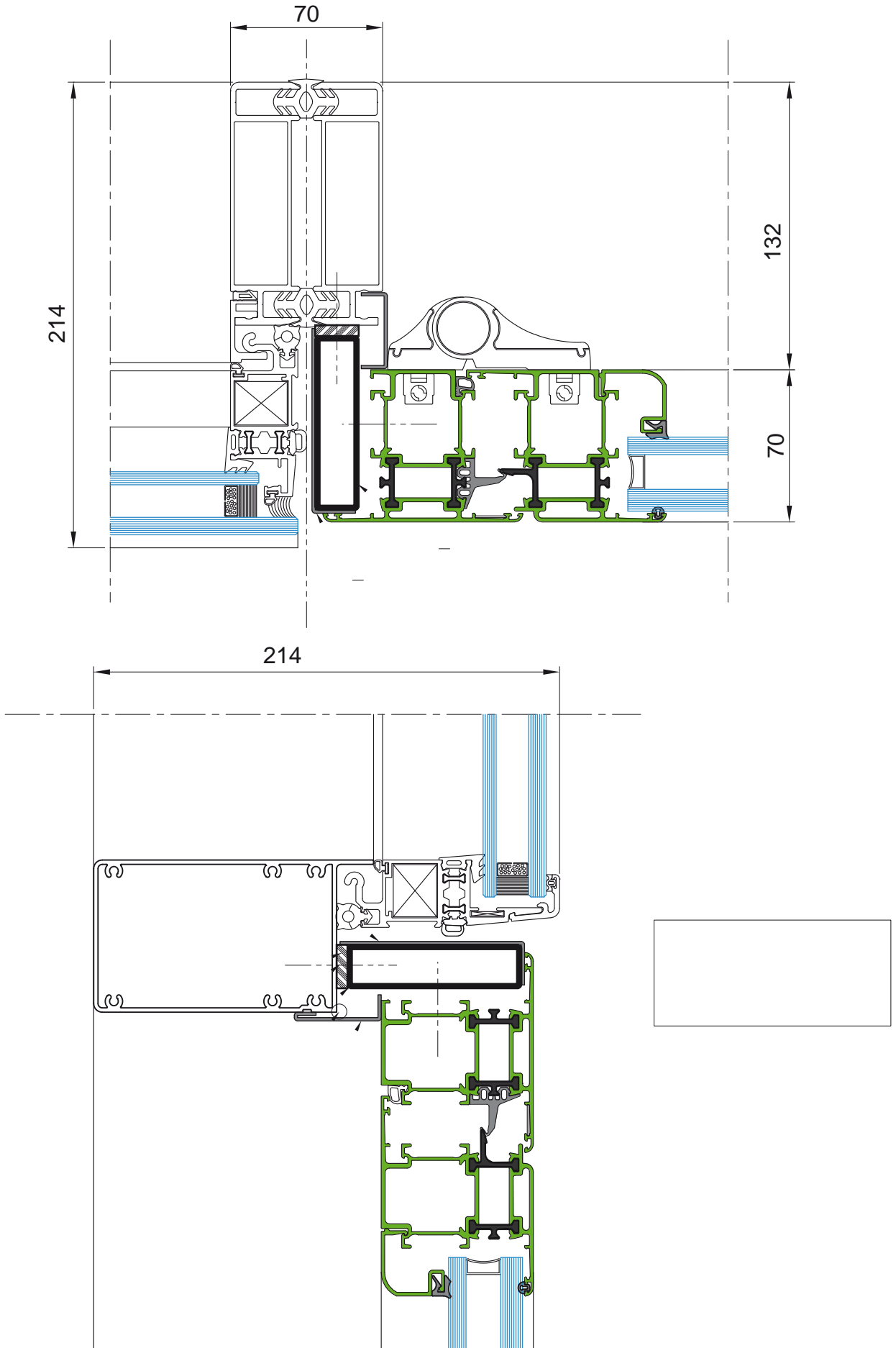



Statik Deęerler Strength Characteristics

Profil Kesitleri 90°
Cutting profiles all 90°

yükseltici Mullion 20.00.200.XX

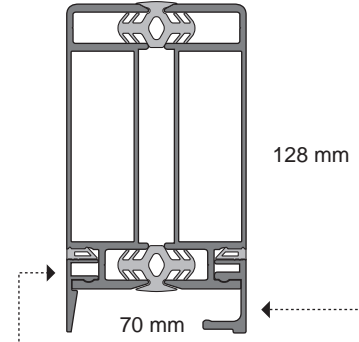
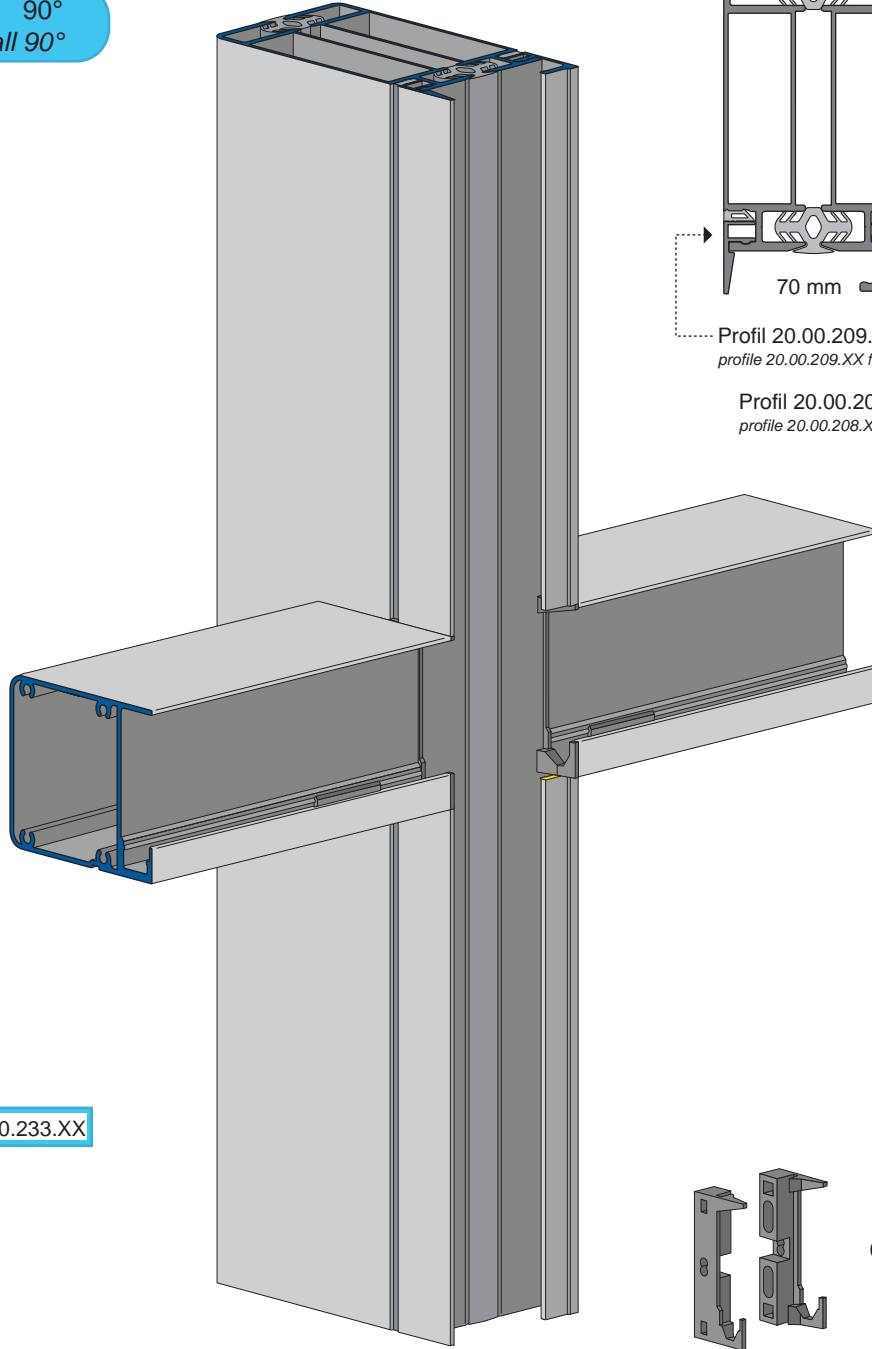

Profil 20.00.209.XX açılır kanat
profile 20.00.209.XX for extendable wing

Profil 20.00.208.XX sabit kanat
profile 20.00.208.XX for fixed wing

traverso/transom 20.00.233.XX

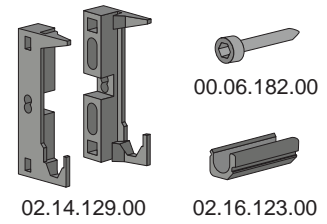
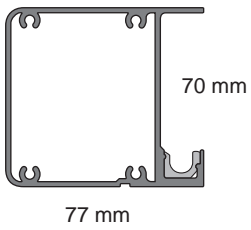

yükseltici (bölüm)
mullion (section)

ATALET MOMENTİ $J_{xx} = 221.1 \text{ cm}^4$
Inertia moment $J_{xx} = 221.1 \text{ cm}^4$

MUKAVEMET $W_{xx} = 39.11 \text{ cm}^3$
Resistance form $W_{xx} = 39.11 \text{ cm}^3$

ağırlık/weight 4.42 Kg/m

traverso (bölüm)
transom (section)

Atalet Mom./inertia moment $J_{xx} = 54.19 \text{ cm}^4$

Atalet Mom./inertia moment $J_{yy} = 40.00 \text{ cm}^4$

Mukavemet/resist. form $W_{xx} = 14.28 \text{ cm}^3$

Mukavemet/resist. form $W_{yy} = 10.68 \text{ cm}^3$

ağırlık/weight 1.753 Kg/m

CONTA
gaskets



00.40.858.00



00.40.859.00

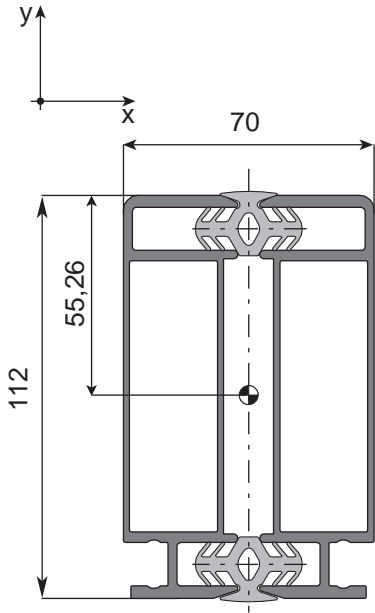

Rüzgar yüklü ve destek tipolojisi ile bağlantılı olarak yük kapasitesi Mullions capacity in connection with wind loaded and support typology

Profil/profile 200.XX+200.XX

$$J_x = 221.1 \text{ cm}^4$$

$$W_x = 39.11 \text{ cm}^3$$

Conta ile monte edilmiş 20.00.200.XX kodlu profil koduna (kod 00.40.858.00) ilişkin aşağıdaki çizelgeler, uygulamaya (kış yatırması ve orta dingil mesafesi ile ilgili olarak) bir gösterge değeri verir. Uygulama için hesap ve doğrulama formülüne bakın.

Grafikler için kullanılan değerler şunlardır:

$$f = H/300 \quad s = 880 \text{ kg/cm}^2$$

Grafikler f ve s değişkenlerinin trendi dikkate alınarak hesaplanmıştır.

The charts below, regarding the profile code 20.00.200.XX assembled by gasket (code 00.40.858.00), give an indicative value to the application (with regard to transom and mullion wheelbase).

For application refer to calculus and verification formula.

Used values for charts are:

$$f = H/300 \quad s = 880 \text{ kg/cm}^2$$

Charts were calculated considering the trend of variables f and s .

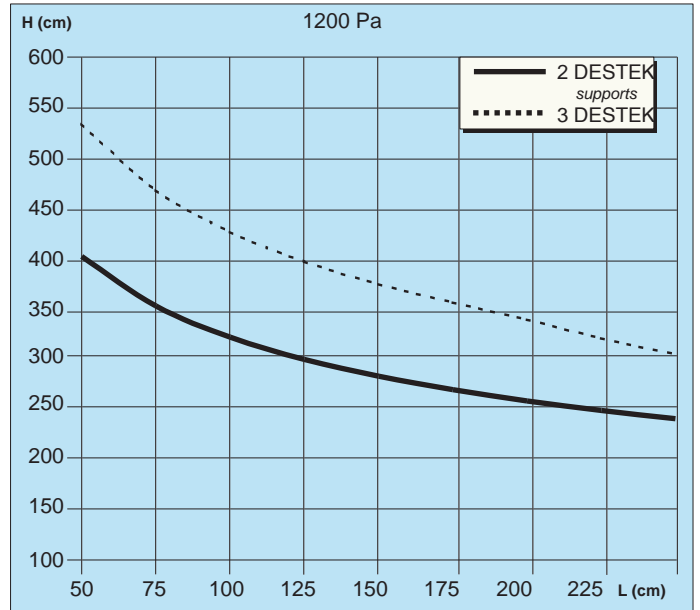
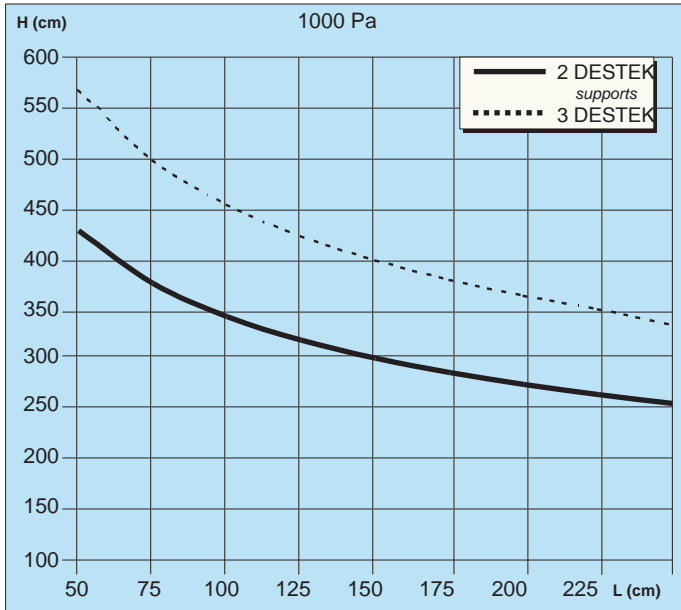
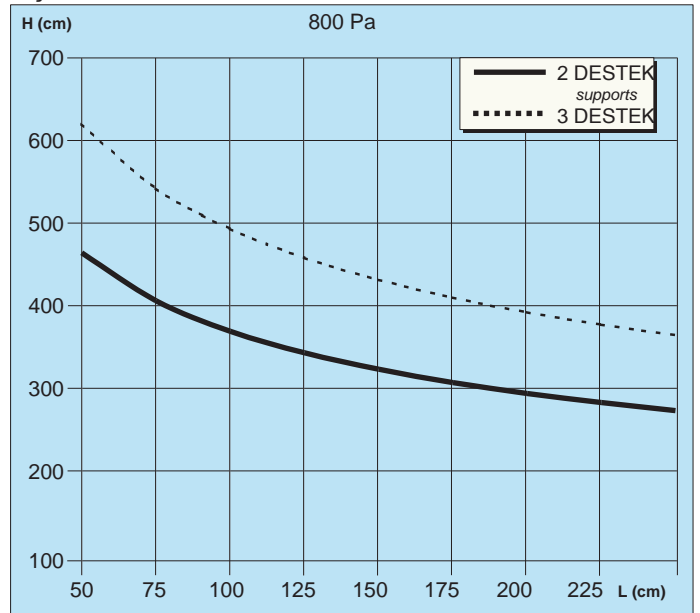
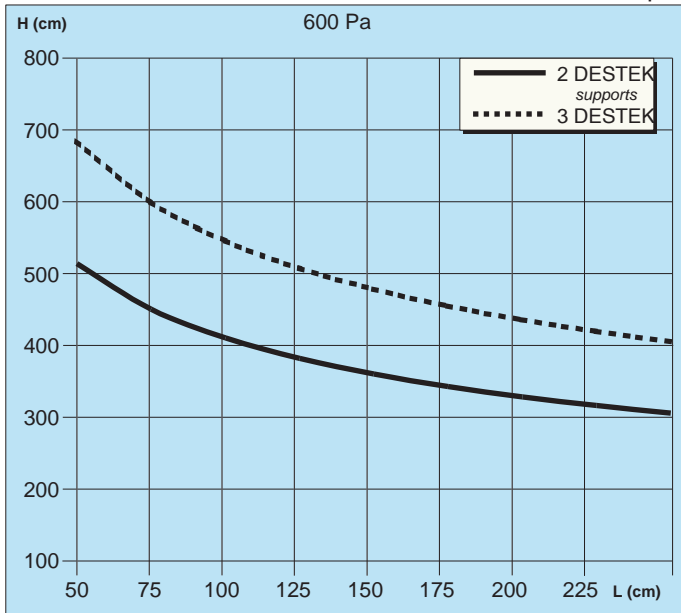

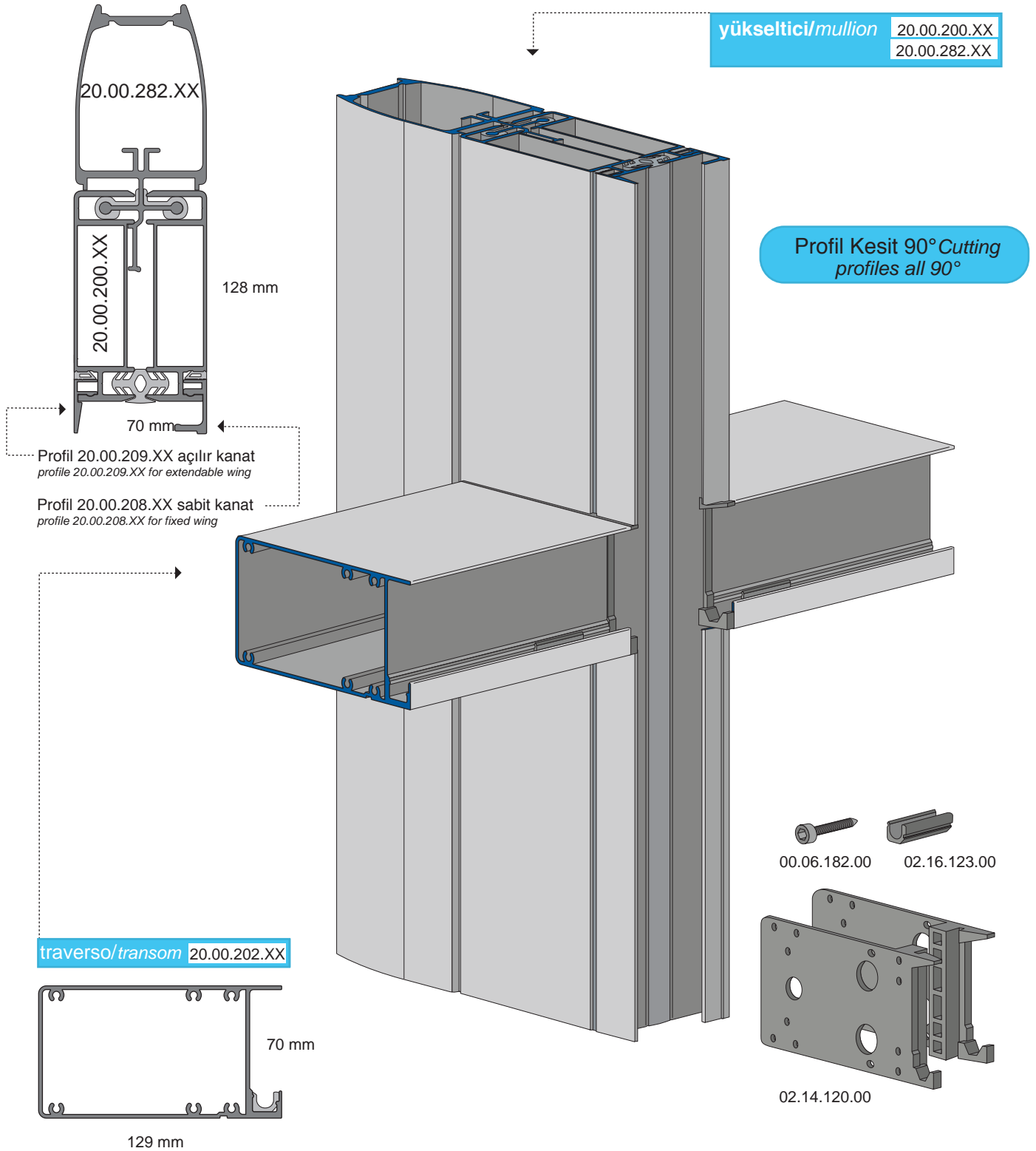

yükseltici(bölüm) mullion (section)

ATALET MOMENTİ $J_{xx} = 445.68$
 cm^4 Inertia moment $J_{xx} = 445.68$ cm^4

MUKAVEMET $W_{xx} = 57.6$ cm^3
Resistance form $W_{xx} = 57.6$ cm^3

ağırlık/weight 7.988 Kg/m

traverso (bölüm) transom (section)

Atalet Mom./inertia moment $J_{xx} = 88.98$ cm^4

Atalet Mom./inertia moment $J_{yy} = 195.51$ cm^4

Mukavemet/resist. form $W_{xx} = 24.09$ cm^3

Mukavemet/resist. form $W_{yy} = 29.81$ cm^3

ağırlık/weight 2.723 Kg/m

CONTA gaskets



00.40.858.00



00.40.859.00



00.40.908.00

Rüzgar yüklü ve destek tipolojisi ile bağlantılı olarak yük kapasitesi
Mullions capacity in connection with wind loaded and support typology

Profil/profile 200.XX+200.XX+282X..

$$J_x=445.68 \text{ cm}^4$$

$$W_x=57.6 \text{ cm}^3$$

Conta ile monte edilmiş 20.00.200.XX kodlu profil koduna (kod 00.40.858.00) ilişkin aşağıdaki çizelgeler, uygulamaya (kış yatırması ve orta dingil mesafesi ile ilgili olarak) bir gösterge değeri verir. Uygulama için hesap ve doğrulama formülüne bakın.

Grafikler için kullanılan değerler şunlardır:

$$f=H/300 \quad s=880 \text{ kg/cm}^2$$

Grafikler f ve s değişkenlerinin trendi dikkate alınarak hesaplanmıştır.

The charts below, regarding the profile code 20.00.200.XX assembled by gasket (code 00.40.858.00), give an indicative value to the application (with regard to transom and mullion wheelbase).

For application refer to calculus and verification formula.

Used values for charts are:

$$f=H/300 \quad s=880 \text{ kg/cm}^2$$

Charts were calculated considering the trend of variables f and s .

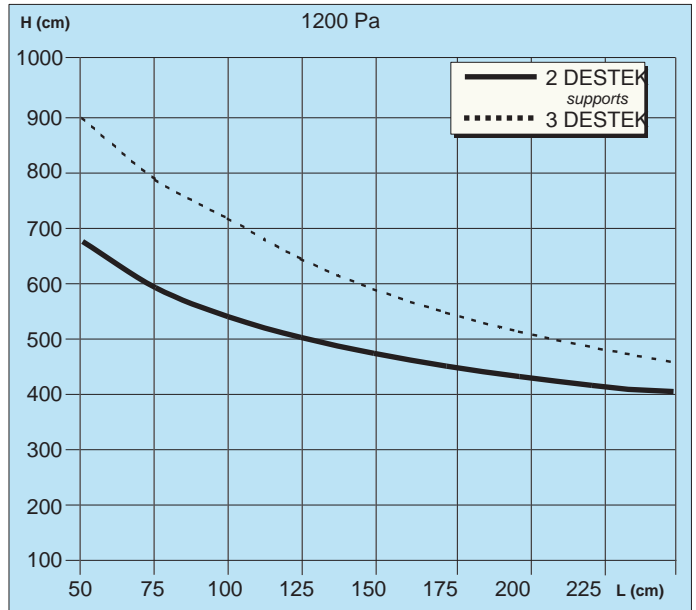
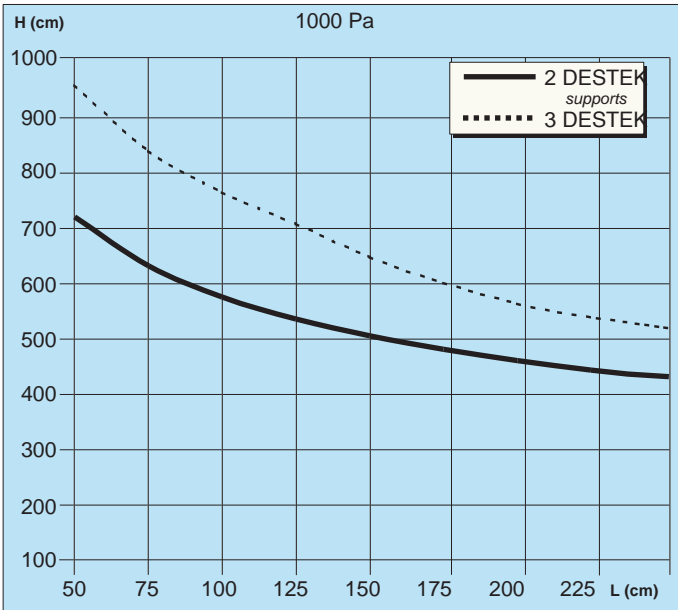
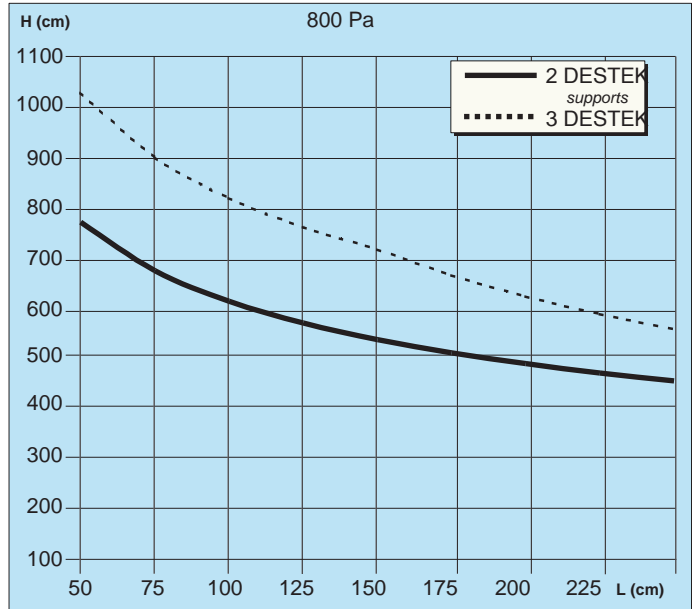
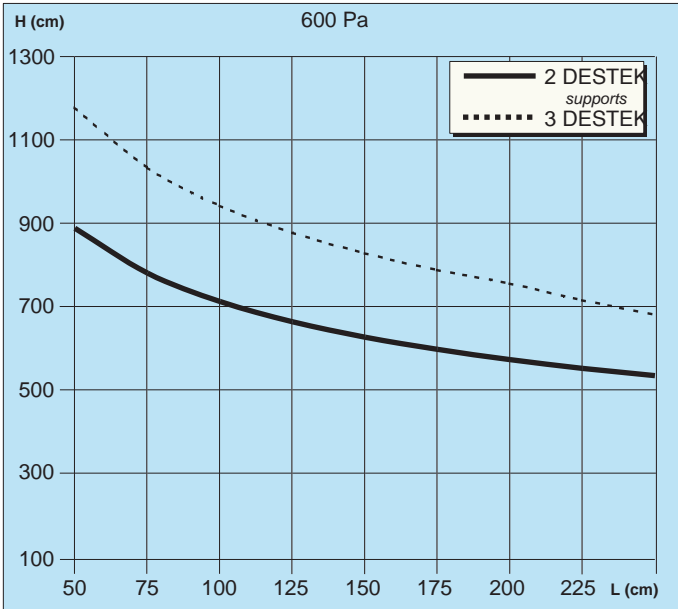
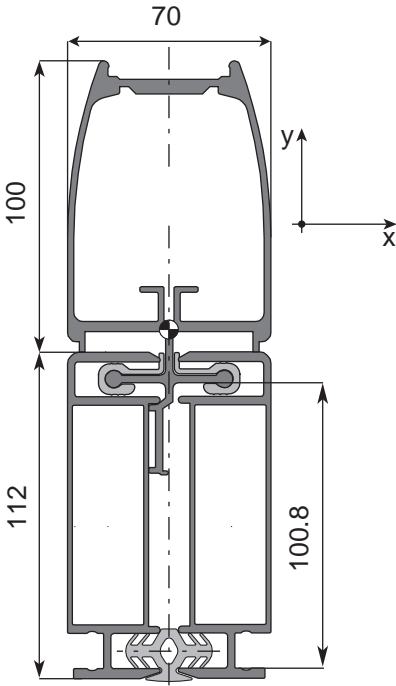

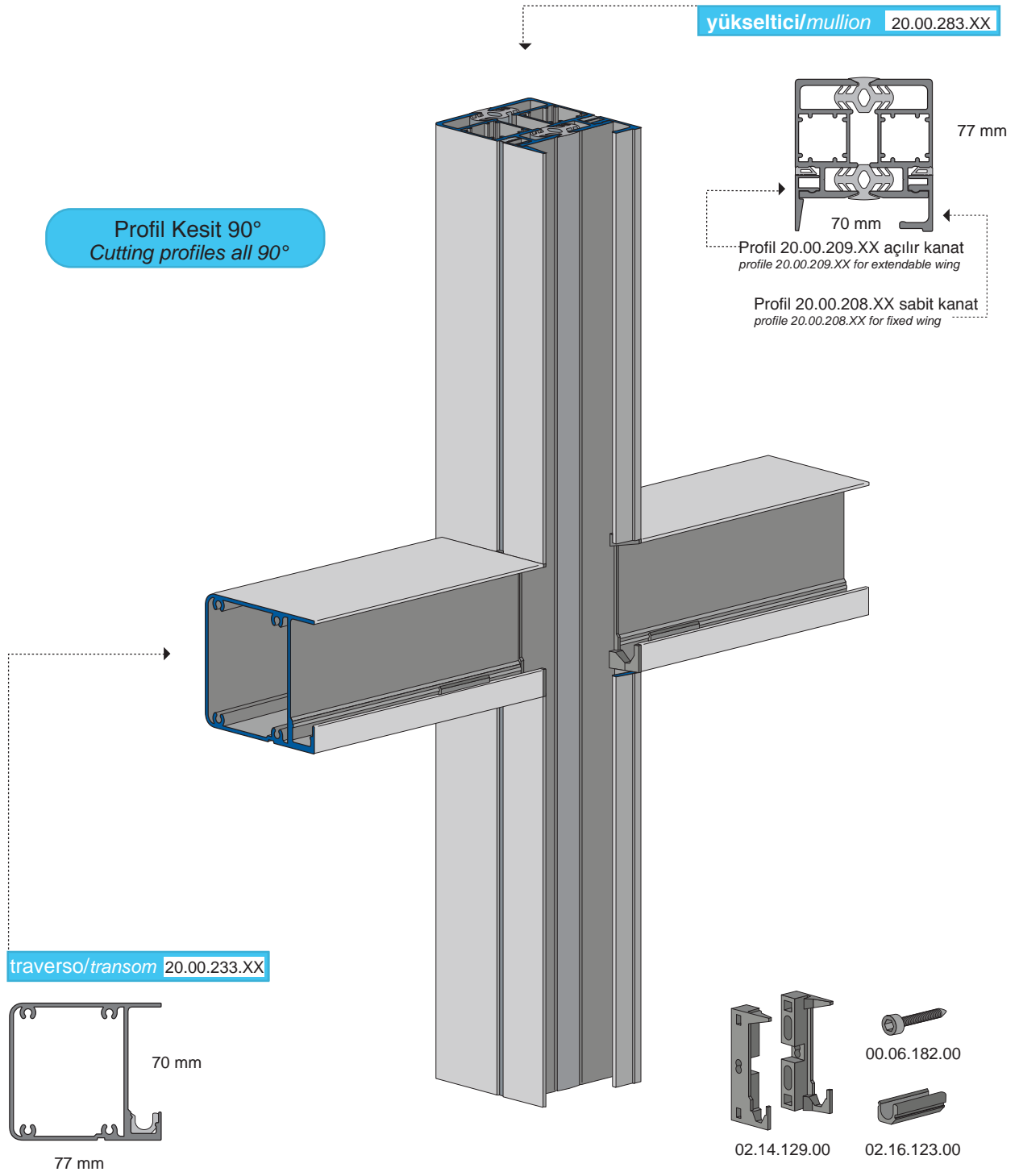

yükseletici (bölüm) mullion (section)

ATALET MOMENTİ $J_{xx} = 43.56 \text{ cm}^4$
Inertia moment $J_{xx} = 43.56 \text{ cm}^4$

MUKAVEMET $W_{xx} = 14.62 \text{ cm}^3$
Resistance form $W_{xx} = 14.62 \text{ cm}^3$

ağırlık/weight 3.422 Kg/m

traverso (bölüm) transom (section)

Atalet Mom./inertia moment $J_{xx} = 54.19 \text{ cm}^4$

Atalet Mom./inertia moment $J_{yy} = 40.00 \text{ cm}^4$

Mukavemet/resist. form $W_{xx} = 14.28 \text{ cm}^3$

Mukavemet/resist. form $W_{yy} = 10.68 \text{ cm}^3$

ağırlık/weight 1.753 Kg/m

CONTA gaskets



00.40.858.00



00.40.859.00

Rüzgar yüklü ve destek tipolojisi ile bağlantılı olarak yük kapasitesi Mullions capacity in connection with wind loaded and support typology

Profil/profile 283.XX+283.XX

$$J_x=43.56 \text{ cm}^4$$

$$W_x=14.62 \text{ cm}^3$$

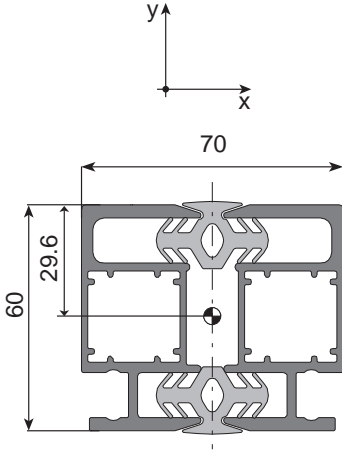

Conta ile monte edilmiş 20.00.283.XX kodlu profil kodu (kod 00.40.858.XX) ile ilgili aşağıdaki çizelgeler, uygulamaya (kış yatırması ve orta dingil mesafesi ile ilgili olarak) bir gösterge değeri verir. Uygulama için hesap ve doğrulama formülüne bakın.

Grafikler için kullanılan değerler şunlardır:

$$f=H/300 \quad s=880 \text{ kg/cm}^2$$

Grafikler f ve s değişkenlerinin trendi dikkate alınarak hesaplanmıştır.

The charts below, regarding the profile code 20.00.283.XX assembled by gasket (code 00.40.858.XX), give an indicative value to the application (with regard to transom and mullion wheelbase).

For application refer to calculus and verification formula.

Used values for charts are:

$$f=H/300 \quad s=880 \text{ kg/cm}^2$$

Charts were calculated considering the trend of variables f and s.

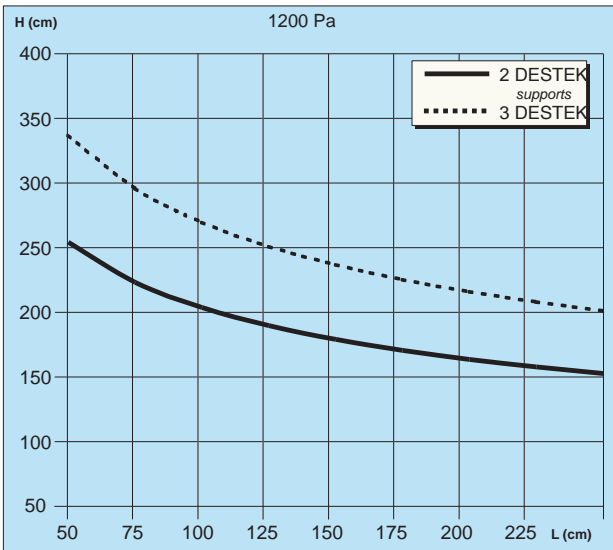
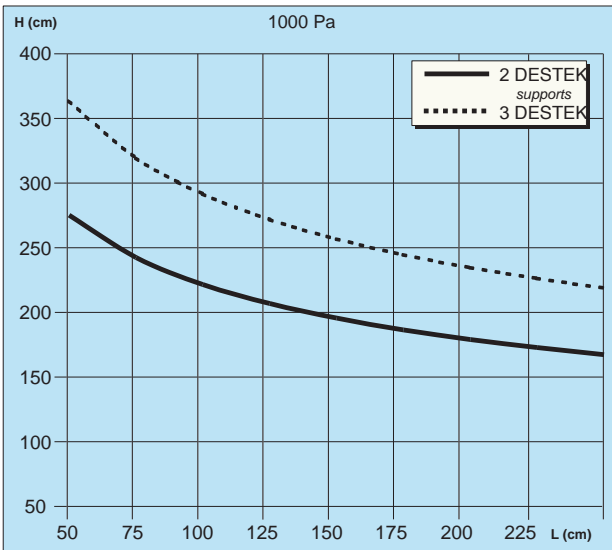
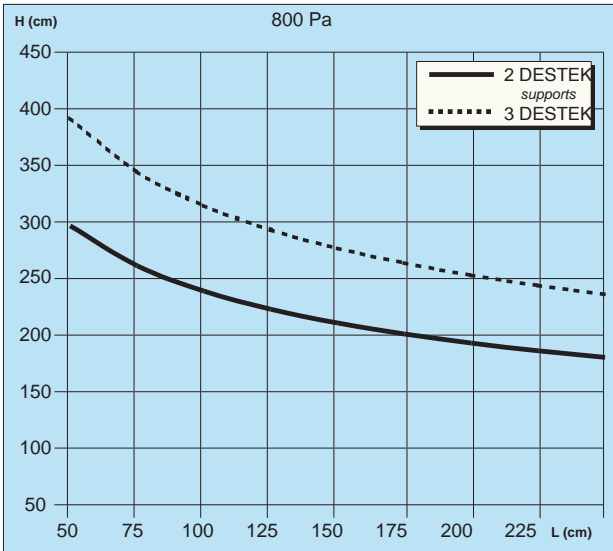
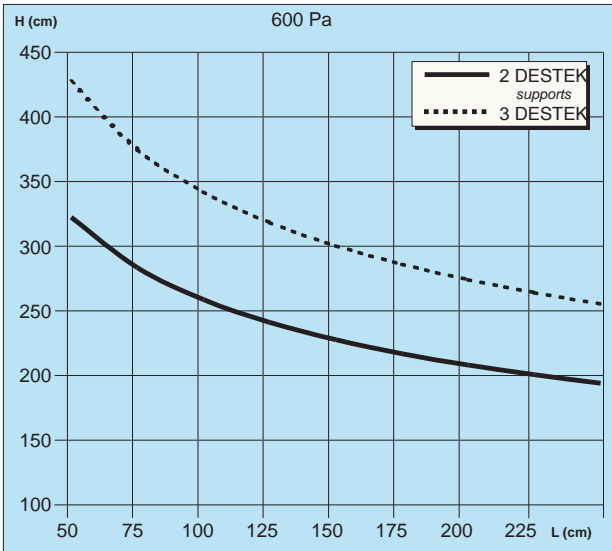

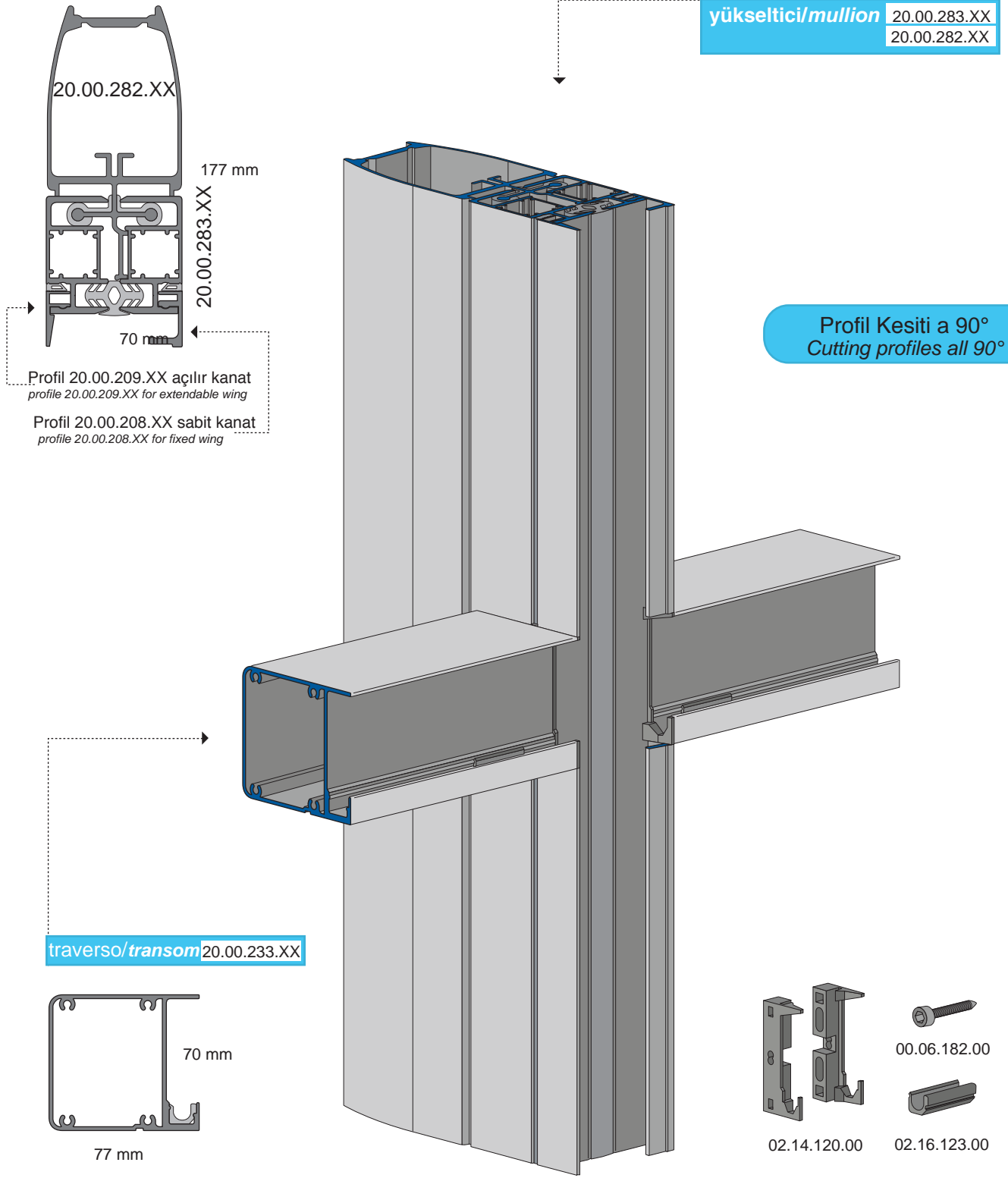

yükseltici (bölüm) mullion (section)

ATALET MOMENTİ $J_{xx} = 268.14 \text{ cm}^4$
Inertia moment $J_{xx} = 268.14 \text{ cm}^4$

MUKAVEMET $W_{xx} = 33.11 \text{ cm}^3$

Resistance form $W_{xx} = 33.11 \text{ cm}^3$

ağırlık/weight 6.99 Kg/m

traverso (bölüm) transom (section)

Atalet Mom./inertia moment $J_{xx} = 54.19 \text{ cm}^4$

Atalet Mom./inertia moment $J_{yy} = 40.00 \text{ cm}^4$

Mukavemet/resist. form $W_{xx} = 14.28 \text{ cm}^3$

Mukavemet/resist. form $W_{yy} = 10.68 \text{ cm}^3$

ağırlık/weight 1.753 Kg/m

CONTA gaskets



00.40.858.00



00.40.859.00



00.40.908.00

Rüzgar yüklü ve destek tipolojisi ile bağlantılı olarak yük kapasitesi
Mullions capacity in connection with wind loaded and support typology

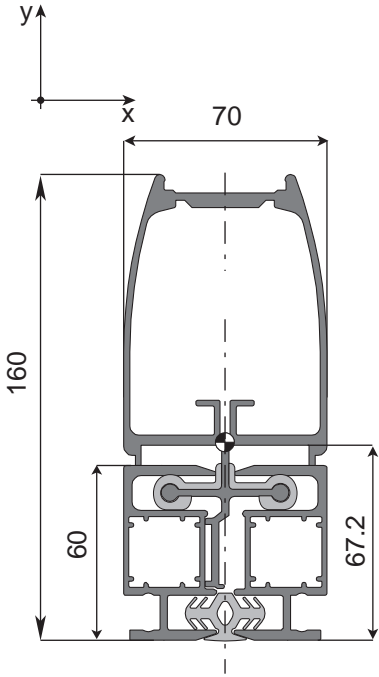

Profil/profile 283.XX+283.XX+282.XX

$$J_x = 268.14 \text{ cm}^4$$

$$W_x = 33.11 \text{ cm}^3$$

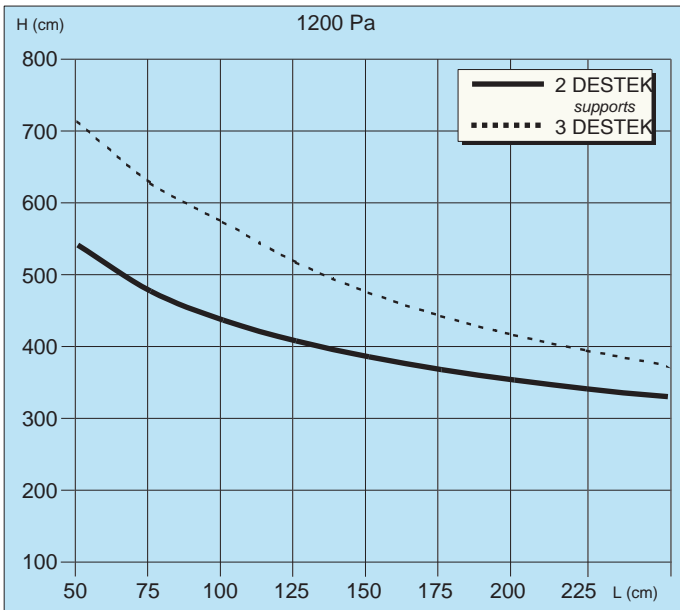
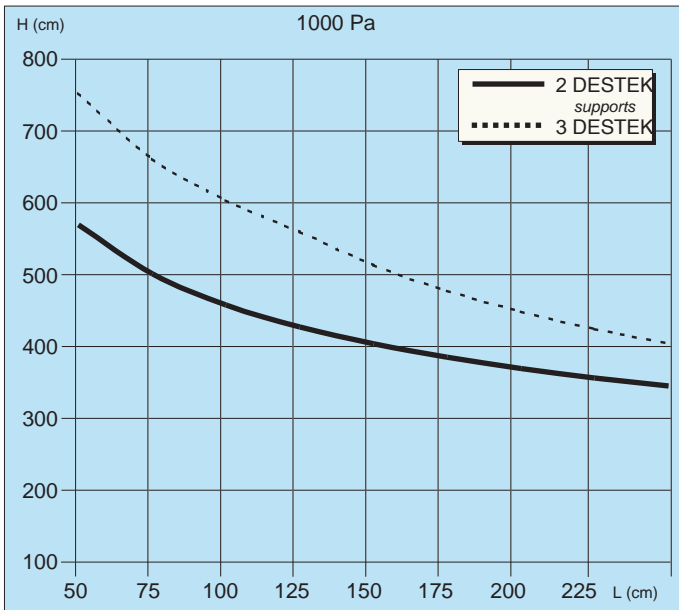
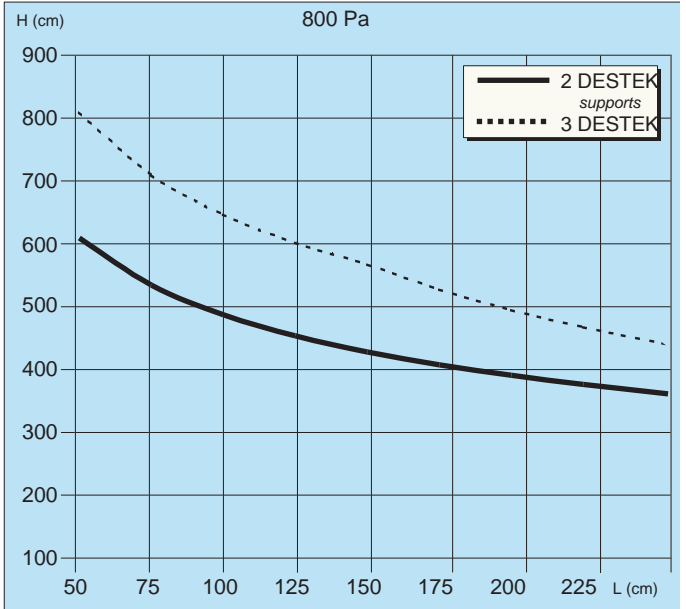
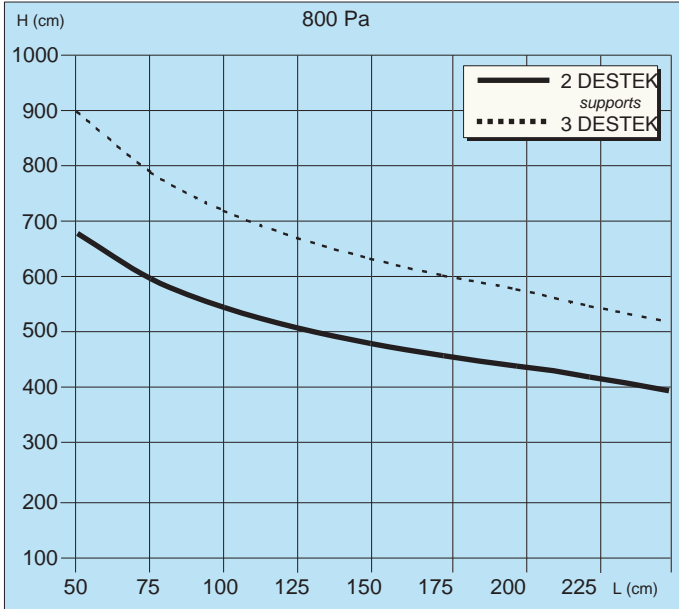



Cephe Sistemleri

Types of Facade



MKAV TT20

GÖZ CONTA

GÖZ CONTA

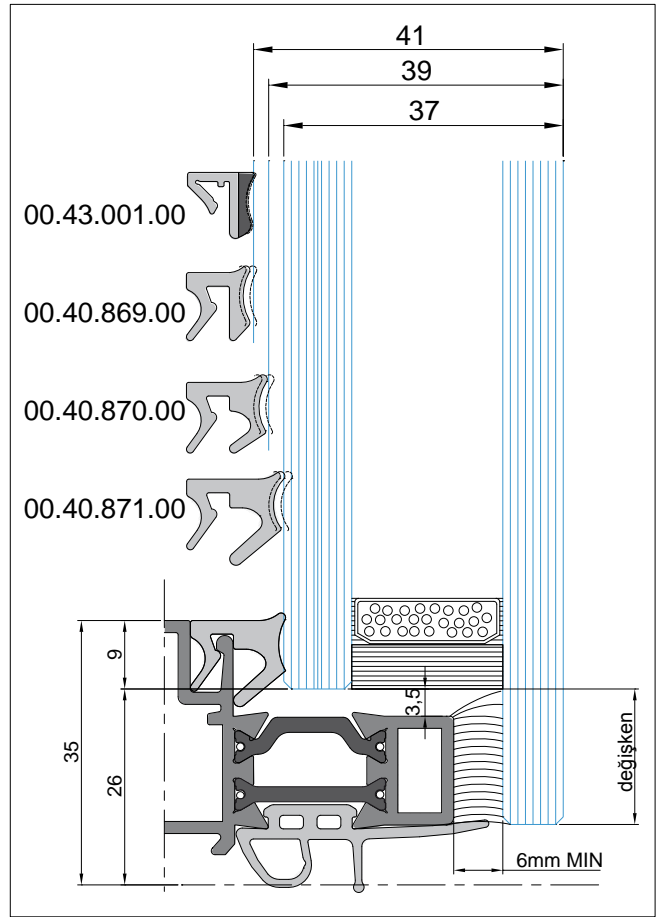
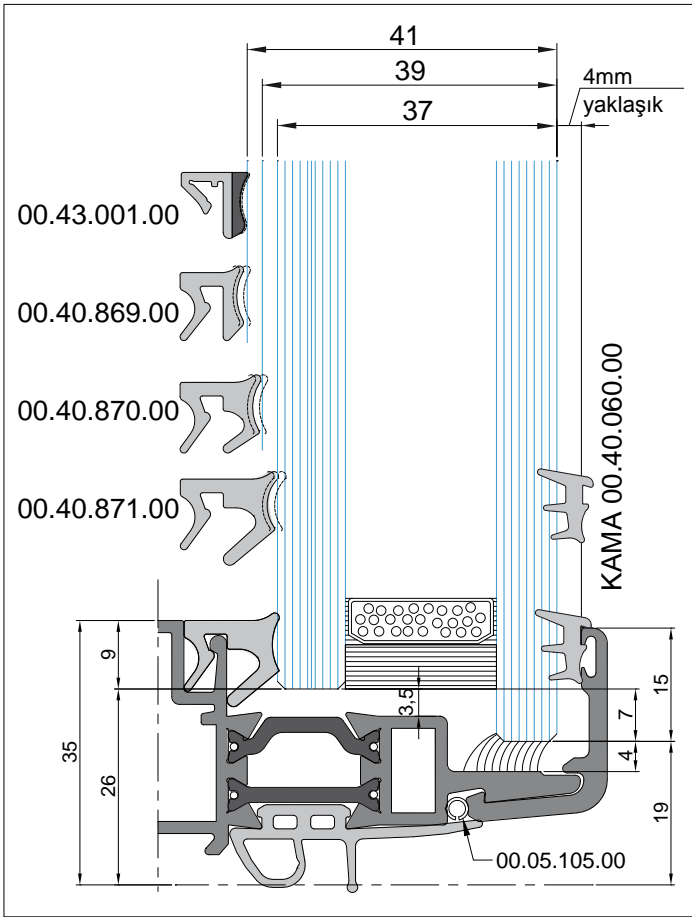
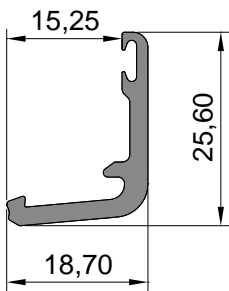
TUTUCU
20.00.022.XX

CAM TİPİ SEÇİMİ İLE İLGİLİ NOTLAR

- İç Cam:
monolitik ise, önerilen minimum kalınlık 6 mm
lamine ise, önerilen minimum bileşim 44.1 (4 + PVB0.38 + 4)
her iki durumda da çevre üzerindeki zemin plakası
- Dış Cam:
minimum kalınlık 8mm "temperlenmiş"
çevre üzerindeki zemin plakası
- NOT: Bunlar yalnızca gösterge niteliğindeki önerilerdir, çünkü camın kalınlığı ve bileşimi her seferinde levhaların boyutuna ve beklenen gerilmelere göre kontrol edilmelidir; Cam tipi seçiminin, camın güvenliği ve ebatları açısından her zaman yürürlükteki mevzuata uygun olarak yapılması gerektiği anlaşılmaktadır.

ÖNEMLİ.

Belirli bir tipolojide kullanılacak dolgunun kalınlığı, aşağıdakiler gibi çeşitli faktörlere bağlı olarak önemli ölçüde değişebilir:

- MKAV profillerinin ve cam çıtalarının ekstrüzyon toleransları;
- CONTA'nın ekstrüzyon toleransları;
- profillerin cila türünün (boyama, oksidasyon, vb.) ve nispi yüzey kalınlığının varyasyonu;
- termal korumanın montajına ilişkin toleranslar;
- dolgunun kendi kalınlığındaki toleranslar.

Bu nedenle, bir sipariş alındıktan sonra, CONTA'ların son siparişinden önce, yukarıda belirtilen varyantları telafi etmek için, uygun dış kamalı contayı seçerek, dolgu uygulamasının her zaman pratik bir kontrolünün yapılması gerekir. katalogdakiler (2,3,4 veya 5mm). Tamamen cam tipi olması durumunda, kontrol edilecek yükseklik cam/alüminyum silikon bağlantının derinliği olacaktır.

MKAV TT20

TAM CAM DİKEY + YATAY MEKANİK TUTUCU
Semistructural wing with horizontal mechanical retain

DİKEY BÖLÜM
horizontal section
22.00.029.XX

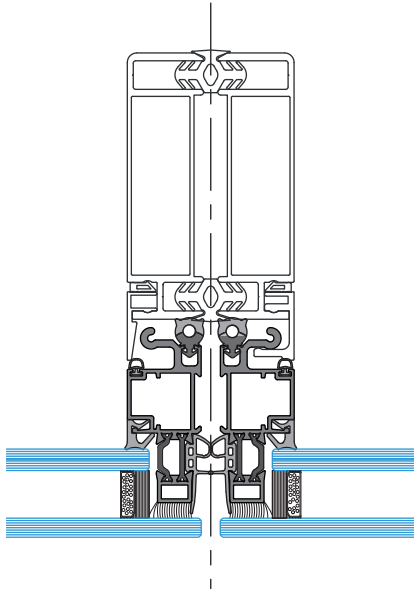

YATAY BÖLÜM
vertical section
22.00.026.XX
20.00.022.XX

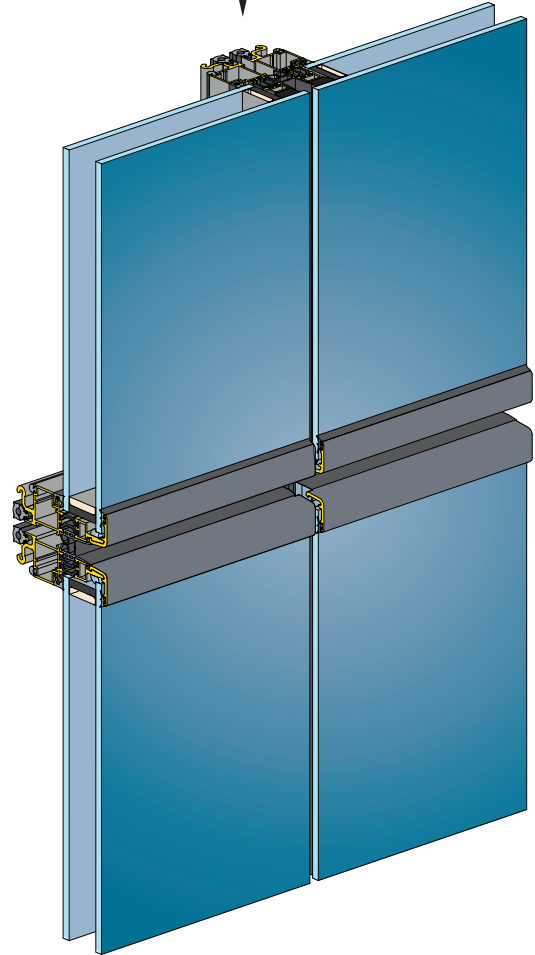
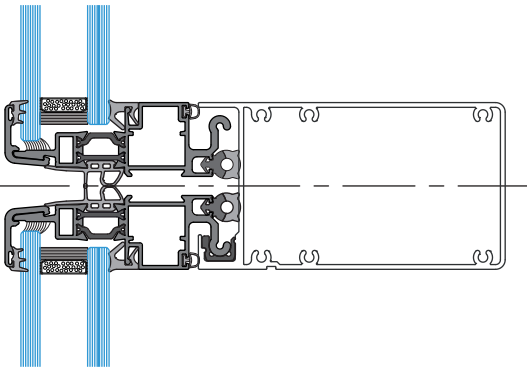

YATAY BÖLÜM
horizontal section

MKAV YARI YAPISAL
Semistructural wing

KALIN ÇİFT CAM. 37 - 41mm
Double glazing (thickness 37-41mm)

ağırlık/weight 2.636 Kg/ml

DİKEY BÖLÜM
vertical section

MKAV YARI YAPISAL
Semistructural wing

KALIN ÇİFT CAM. 37 - 41mm
Double glazing (thickness 37 - 41 mm)

ağırlık/weight 3.482 Kg/ml

CONTA
gaskets

00.40.058.00 00.44.822.00
00.40.046.00
00.40.870.00 00.51.829.00

BÖLÜM 1:1

MKAV TT20

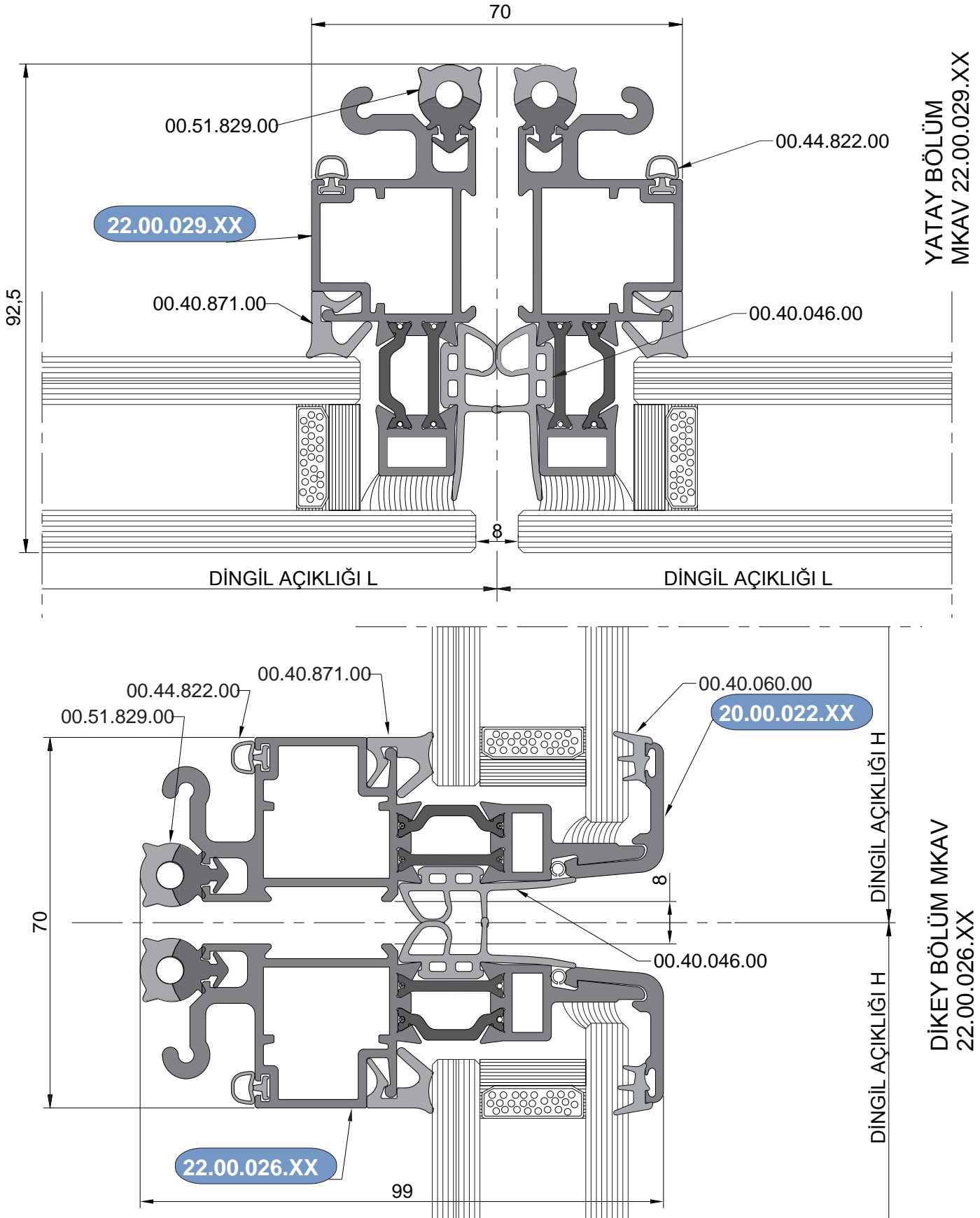

MKAV TT20

KESME VE İŞLEME MASALARI

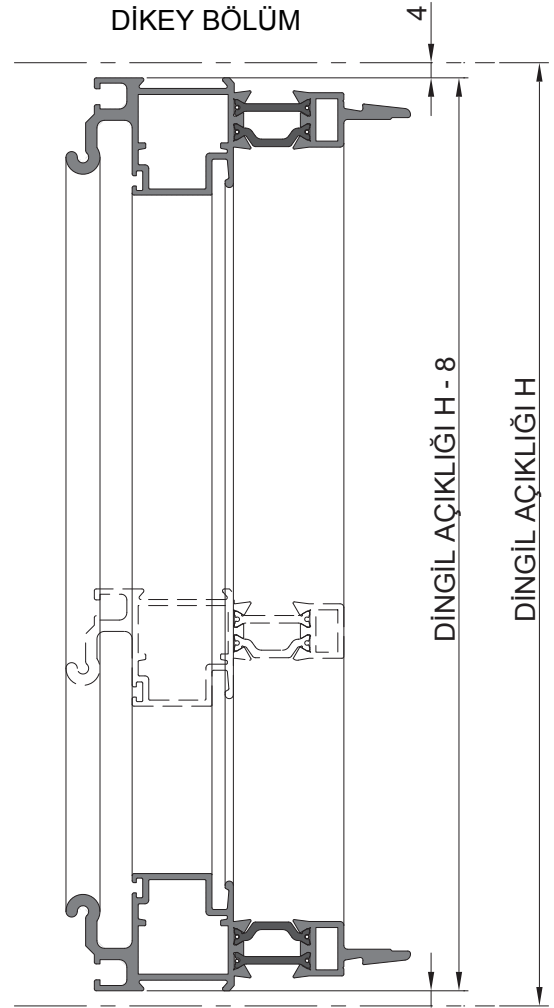
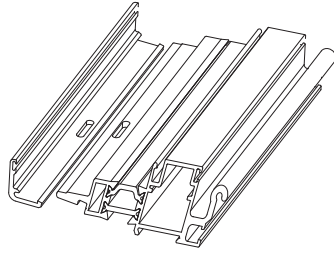
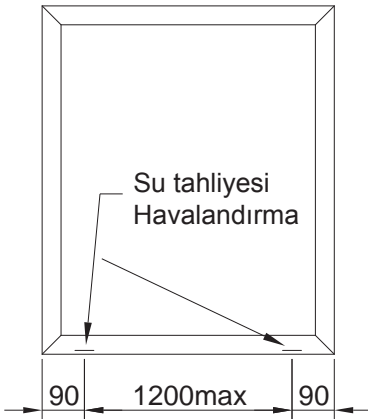
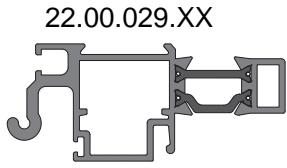
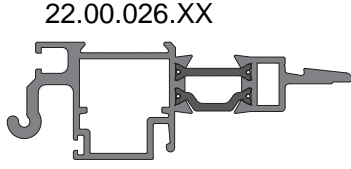

YATAY BÖLÜM

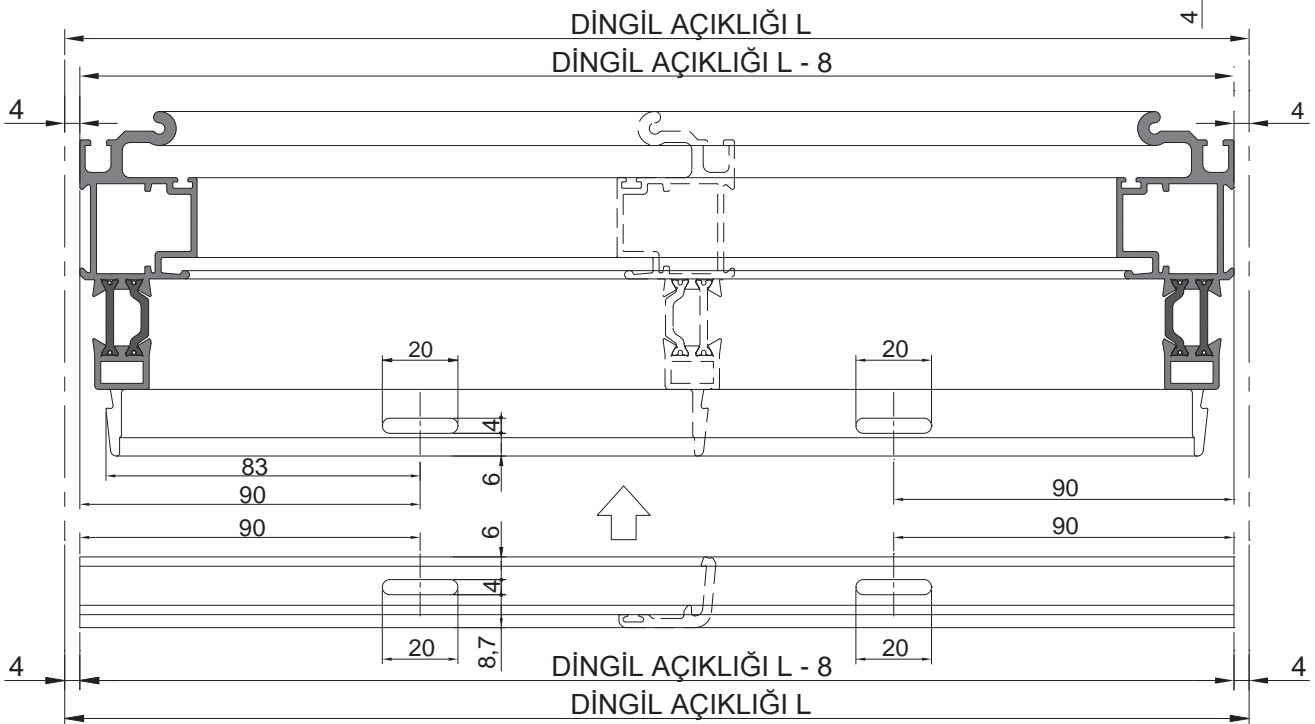

MKAV TT20

cam tutucu çerçeve
perimeter glazing bead

yatay kesit
horizontal section

22.00.026.XX
20.00.022.XX

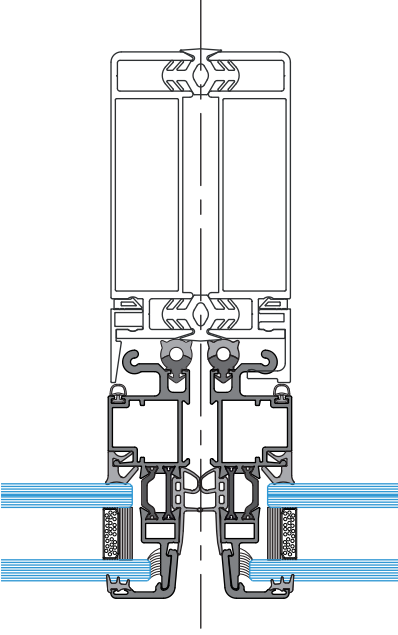

dikey kesit
vertical section

22.00.026.XX
20.00.022.XX

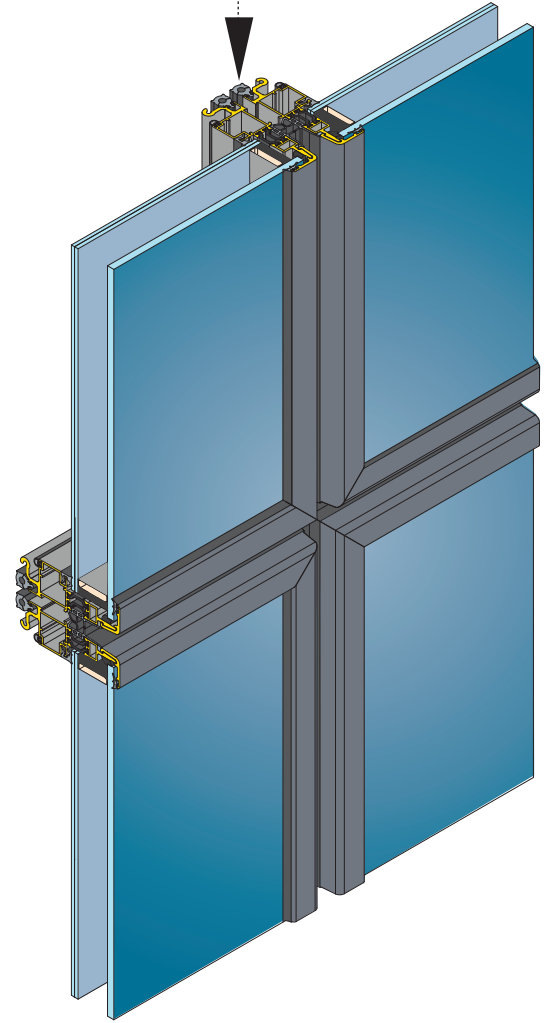
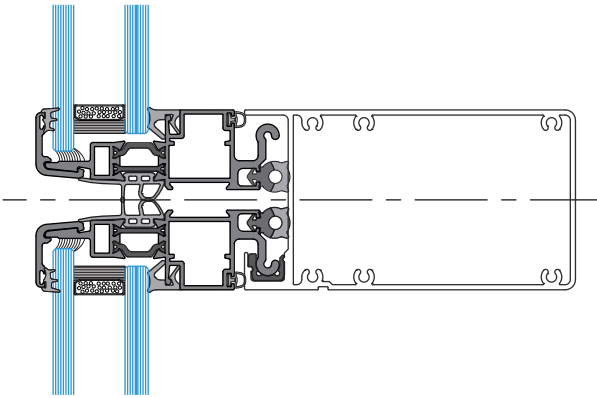

yatay kesit
horizontal section

mekanik sürgülü kanat
mechanical retain wing

Kalın Çift Cam. 37 - 41mm
Double glazing (thickness 37-41mm)

ağırlık/weight 3.482 Kg/ml

dikey kesit
vertical section

mekanik sürgülü kanat
mechanical retain wing

Kalın Çift Cam. 37 - 41mm
Double glazing (thickness 37 - 41 mm)

ağırlık/weight 3.482 Kg/ml

contalar
gaskets

00.40.058.00 00.44.822.00
00.40.046.00
00.40.870.00 00.51.829.00

BÖLÜM 1:1

MKAV TT20

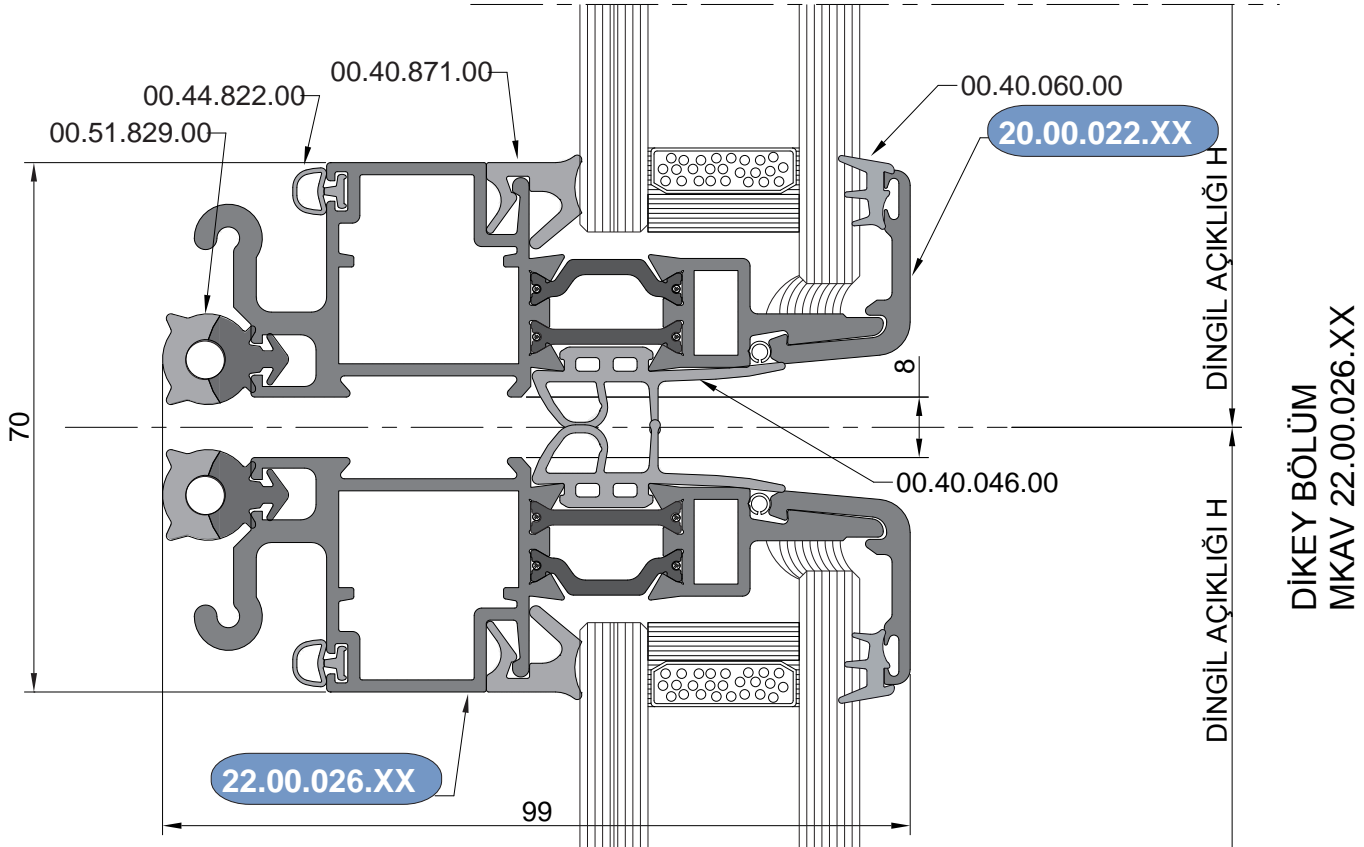
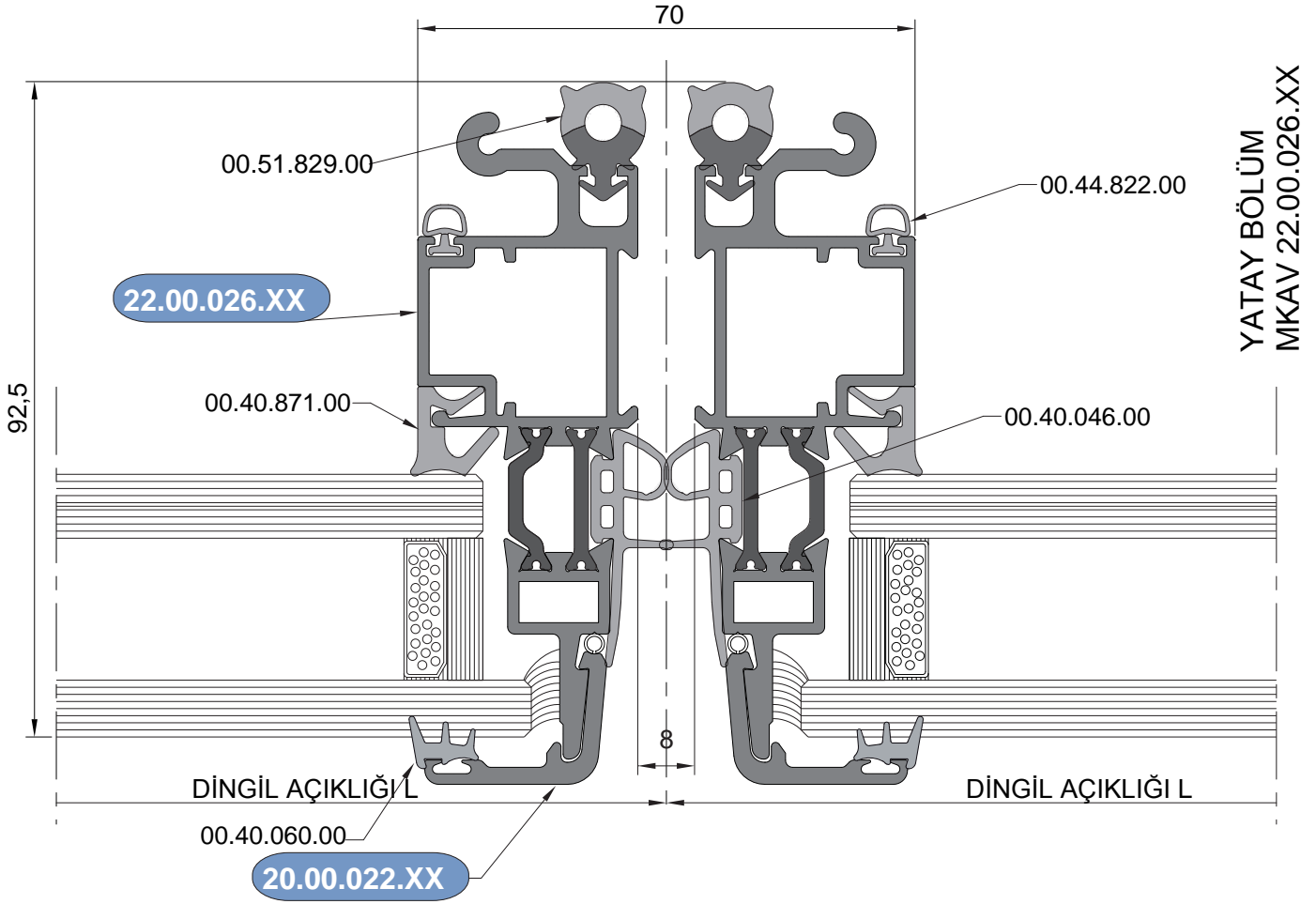

**MKAV
TT20**

KESME VE İŞLEME MASALARI

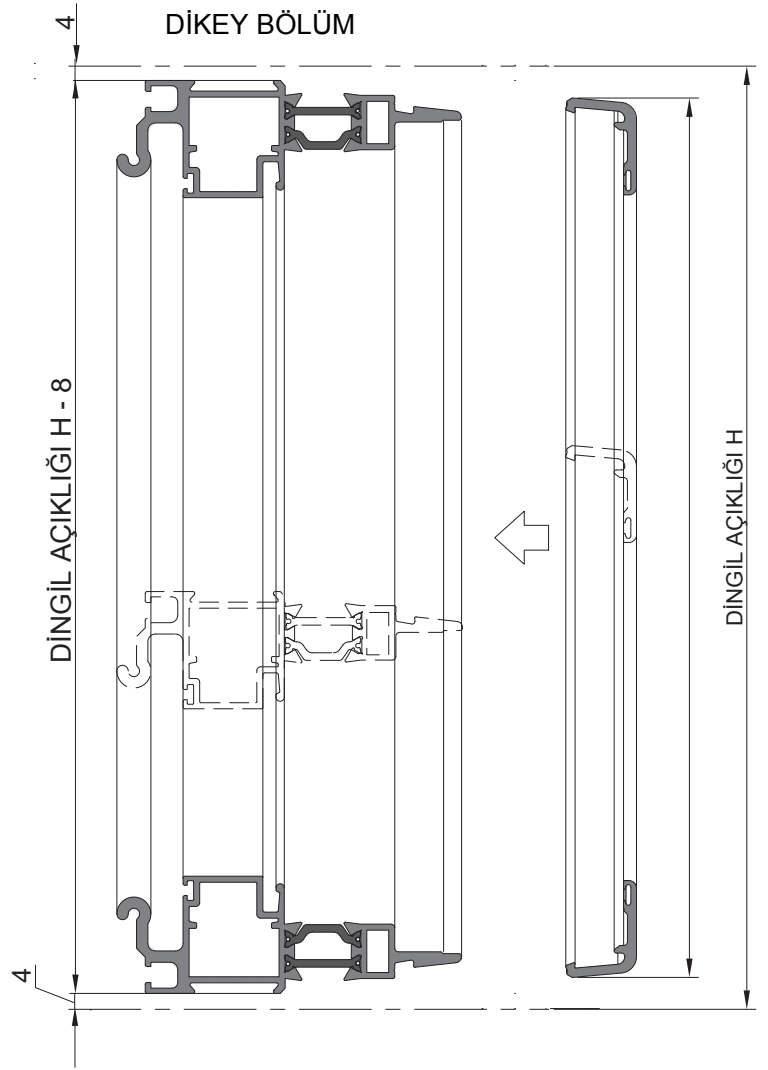
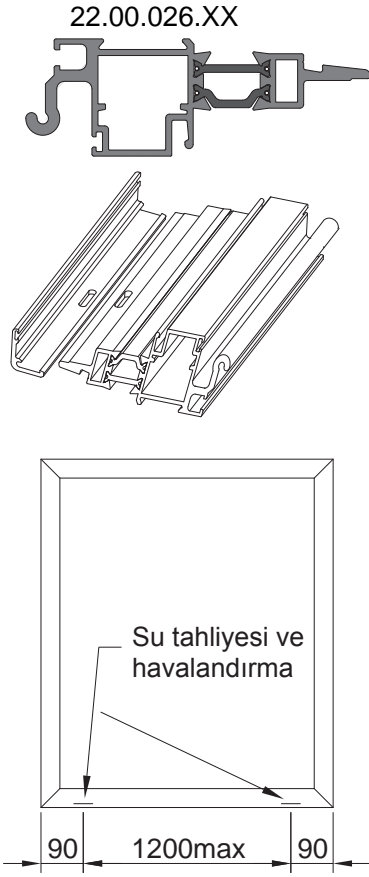

YATAY BÖLÜM

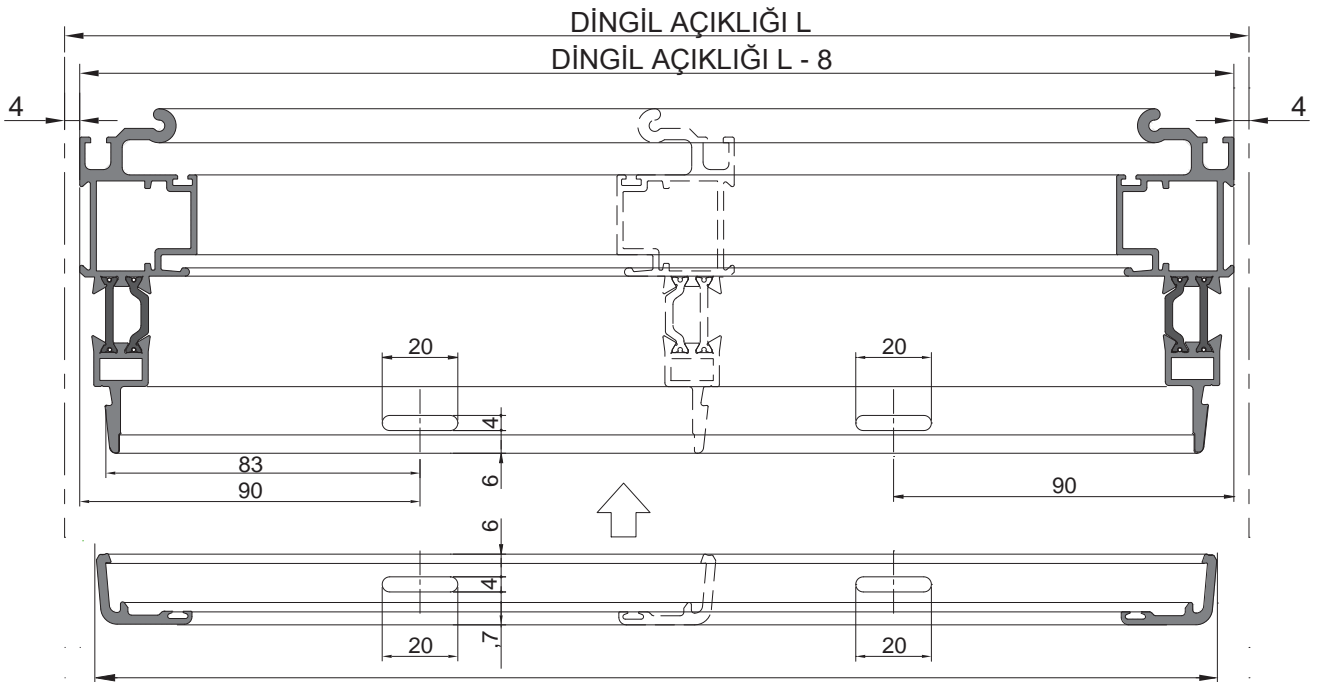

MKAV TT20

YAPISAL
structural

YATAY BÖLÜM 22.00.029.XX
horizontal section

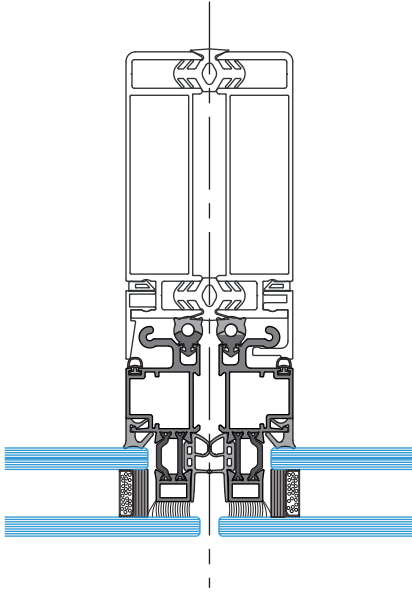

YATAY BÖLÜM 22.00.029.XX

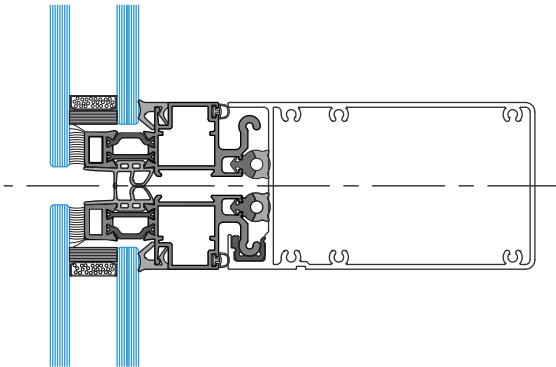

YATAY BÖLÜM
horizontal section

Kanat Yapısı
structural wing

Kalın Çift Cam 37 - 41mm
Double glazing (thickness 37-41mm)

ağırlık/weight 2.636 Kg/ml

DIKEY BÖLÜM
vertical section

Kanat Yapısı
structural wing

Kalın Çift Cam. 37 - 41mm
Double glazing (thickness 37 - 41 mm)

ağırlık/weight 2.636 Kg/ml

CONTA
gaskets

00.44.822.00

00.54.046.00

00.40.870.00

00.51.829.00

BÖLÜM 1:1

MKAV TT20

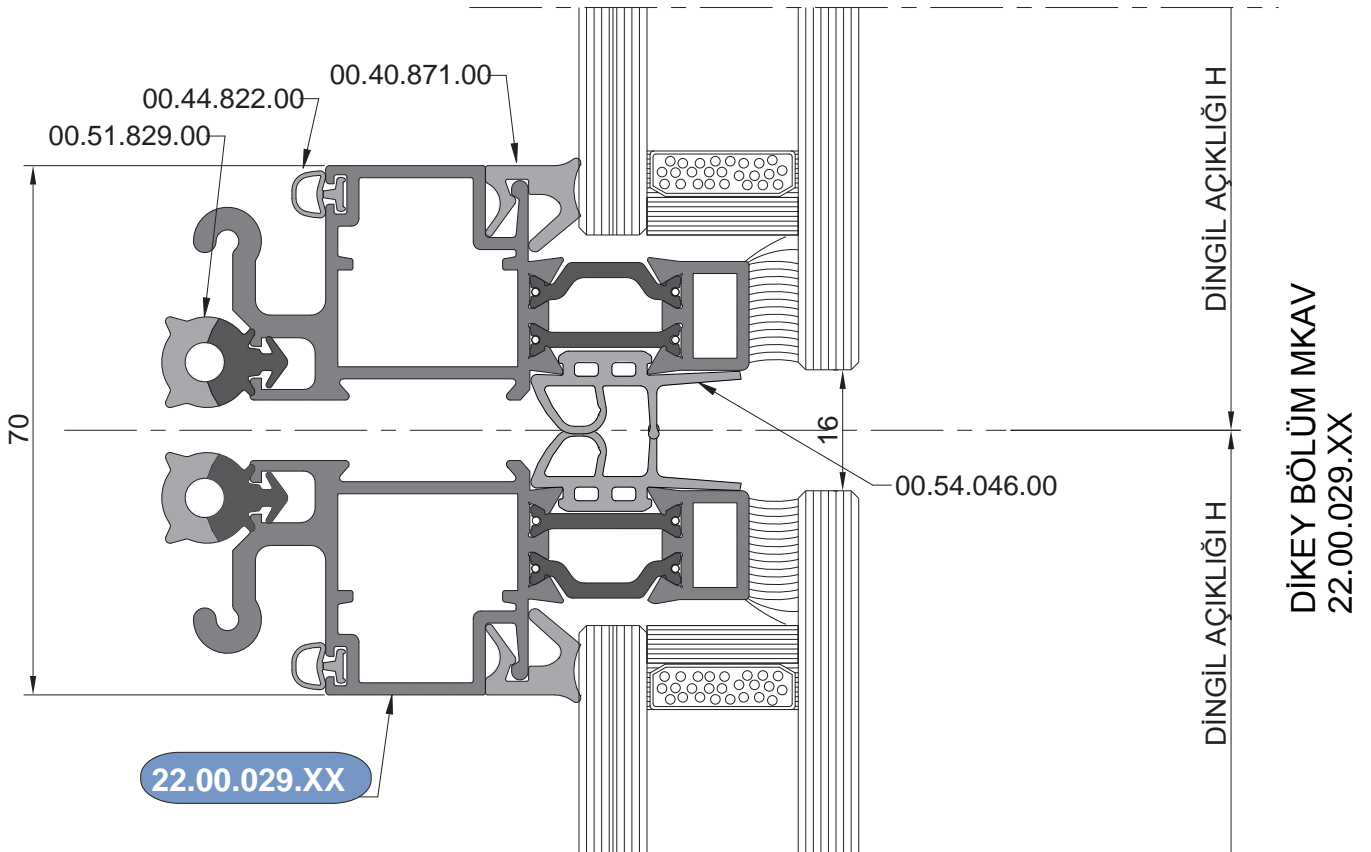
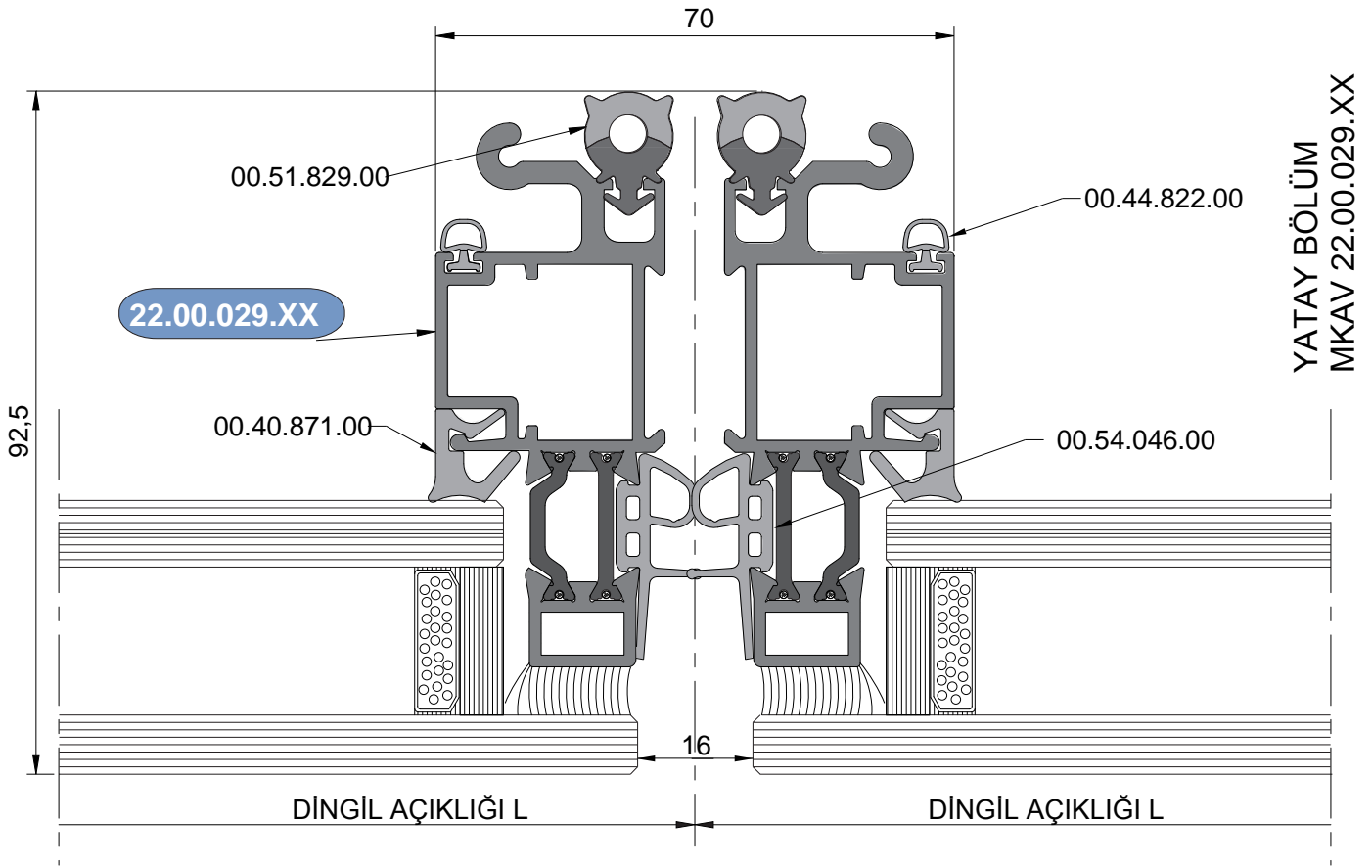

MKAV TT20

KESME VE İŞLEME MASALARI

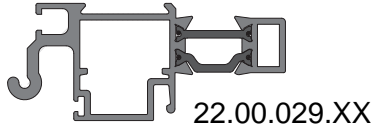

02.16.007.00

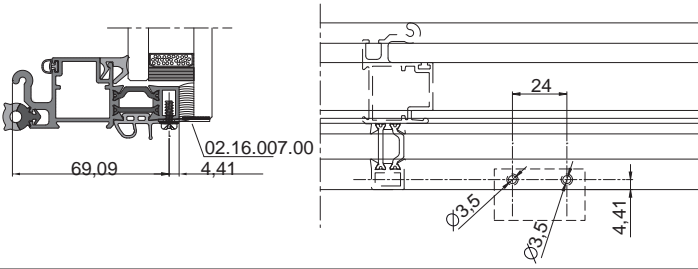

DİKEY BÖLÜM

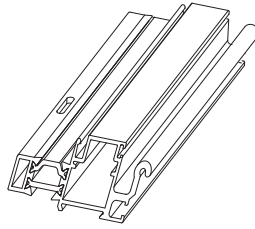
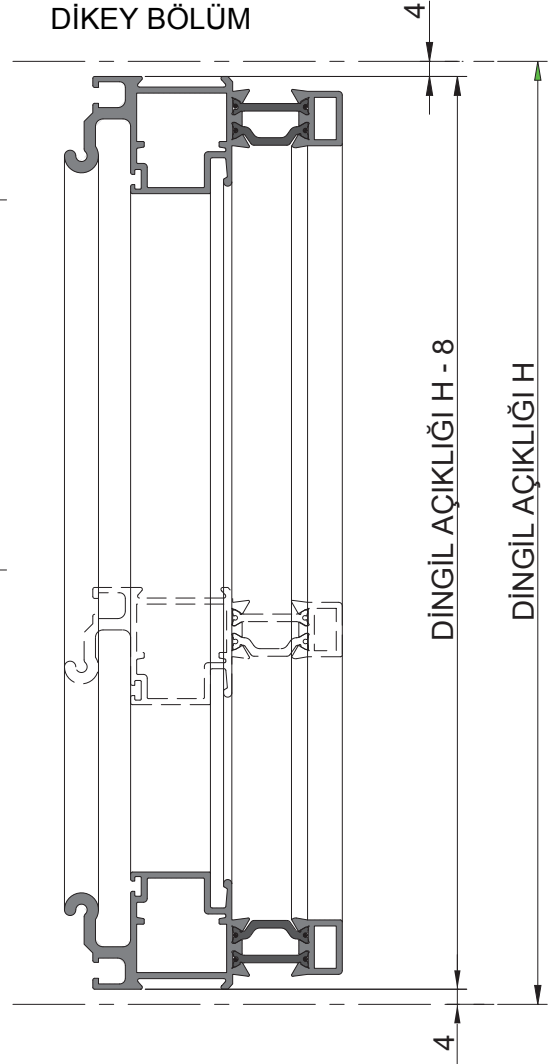

YATAY BÖLÜM

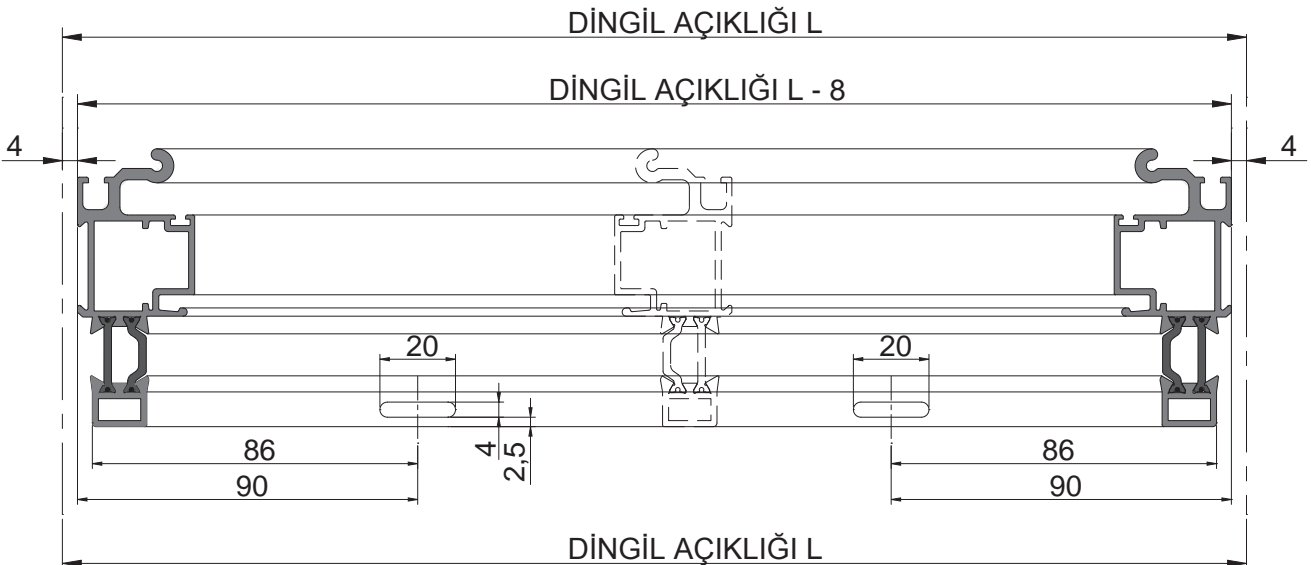



MKAV MEKANİK KANAT SİSTEMİ
MECHANICS SYSTEM WING



DİKEY BÖLÜM 22.00.214.XX
horizontal section

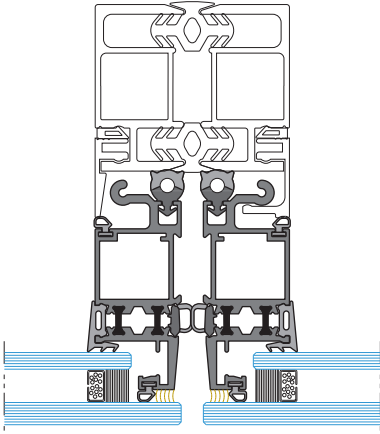

YATAY BÖLÜM 22.00.254.XX
20.00.255.XX

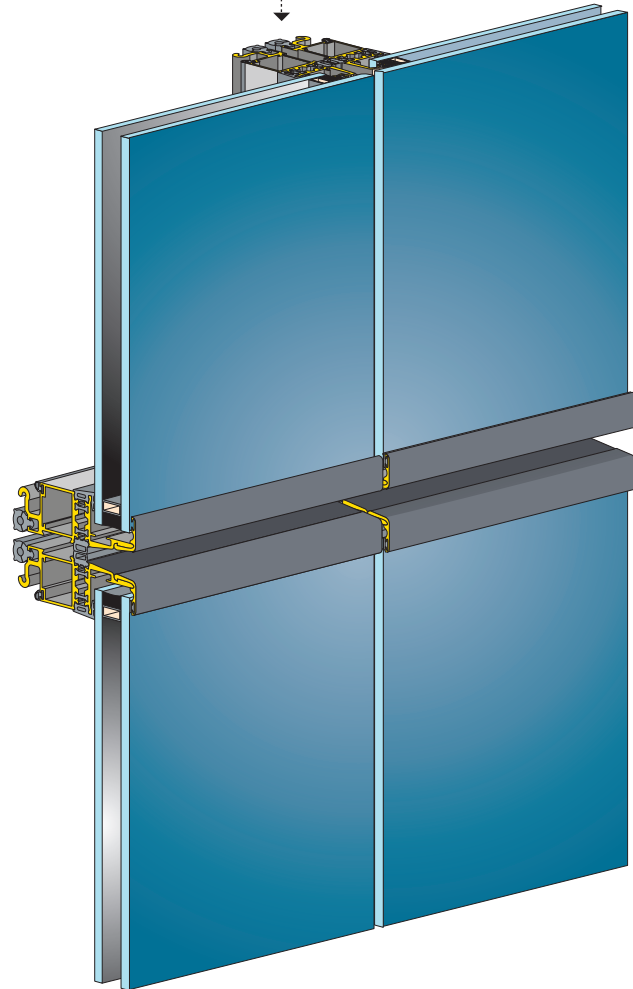
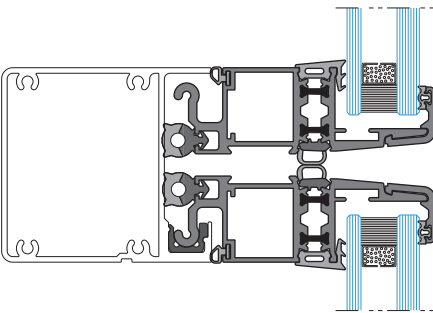

YATAY BÖLÜM
horizontal section

Yalıtımlı Kanat
Thermal break wing

Çift Kalın Cam 28mm
Double glazing (28mm thickness)

ağırlık/weight 3.114 Kg/ml

DİKEY BÖLÜM
vertical section

Dikey Yalıtımlı Sızdırmaz Cam Tut.
Thermal break wing with horizontal glazing bead

Çift Kalın Cam 28mm
Double glazing (28mm thickness)

ağırlık/weight 3.752 Kg/ml

CONTA
gaskets

00.40.734.00



00.44.822.00



00.40.853.00



00.51.829.00



00.40.889.00



YATAY BÖLÜM Horizontal section

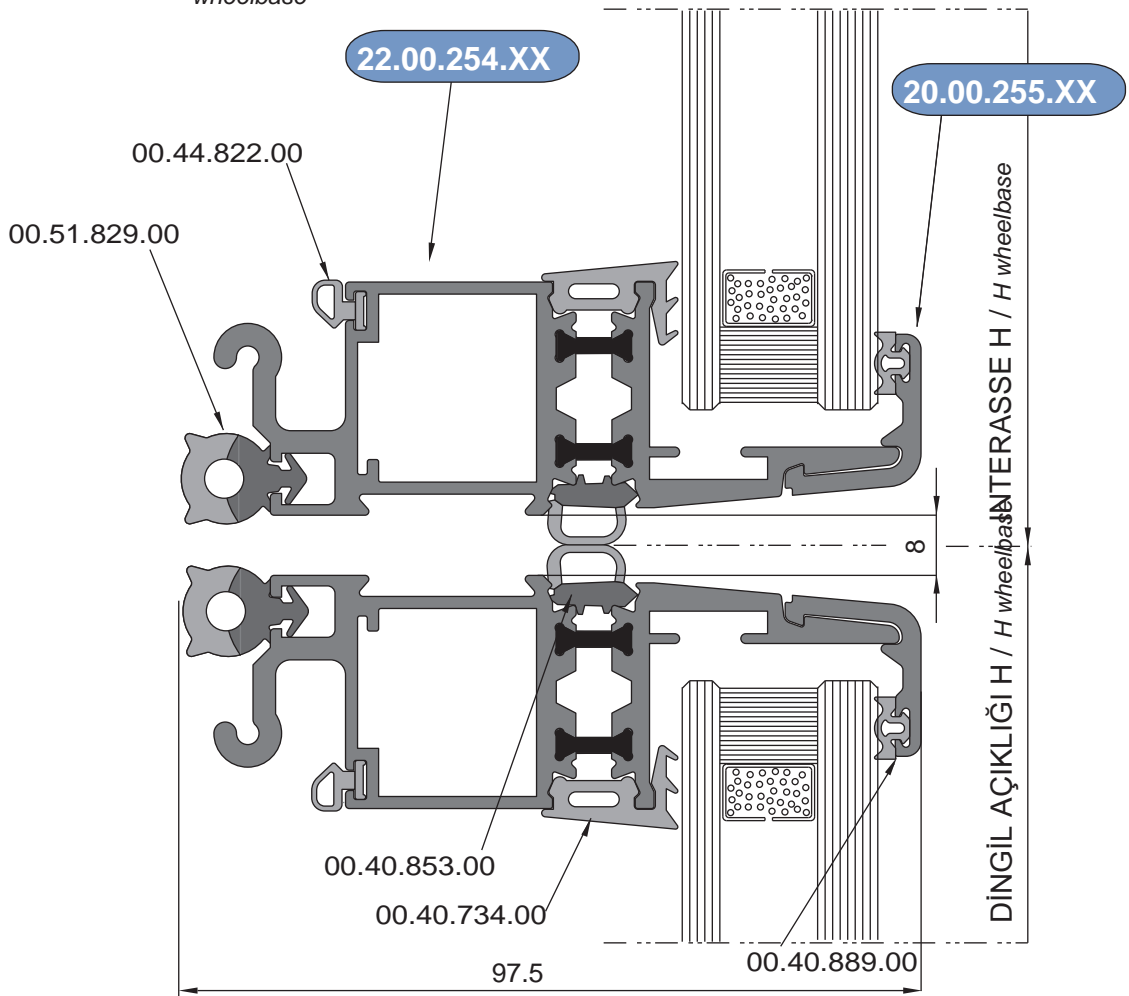
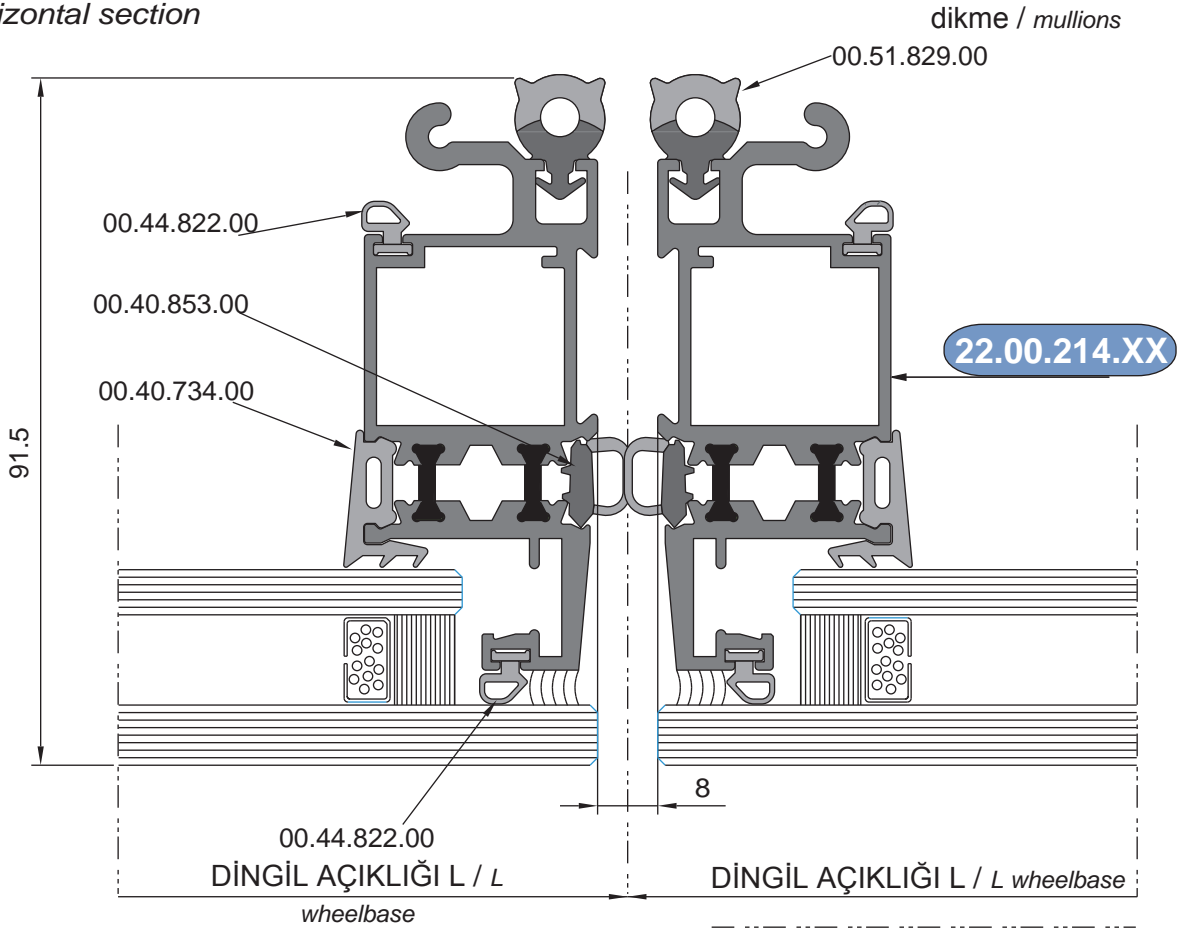

KANAT KESİTLERİ
Cutting wings table

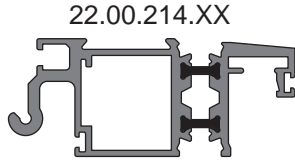
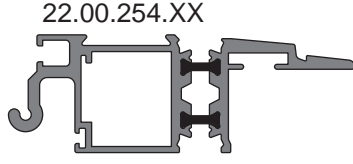

DİKEY BÖLÜM
vertical section

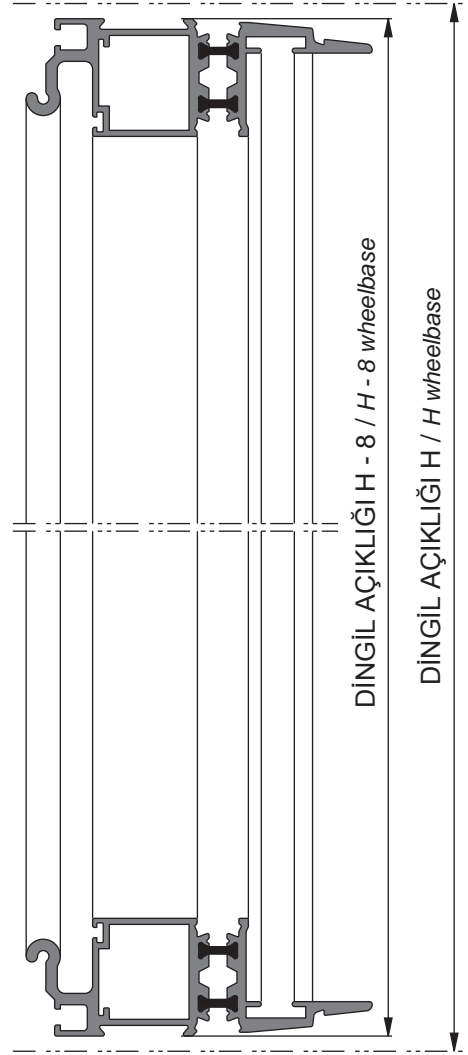

YATAY BÖLÜM
horizontal section

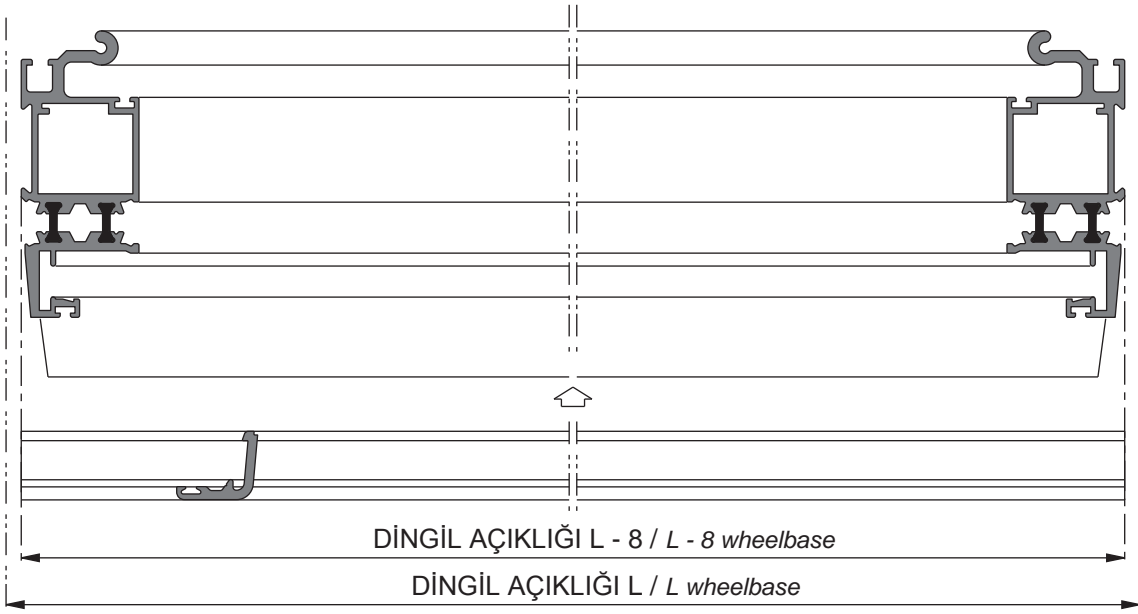

YATAY BÖLÜM Horizontal section

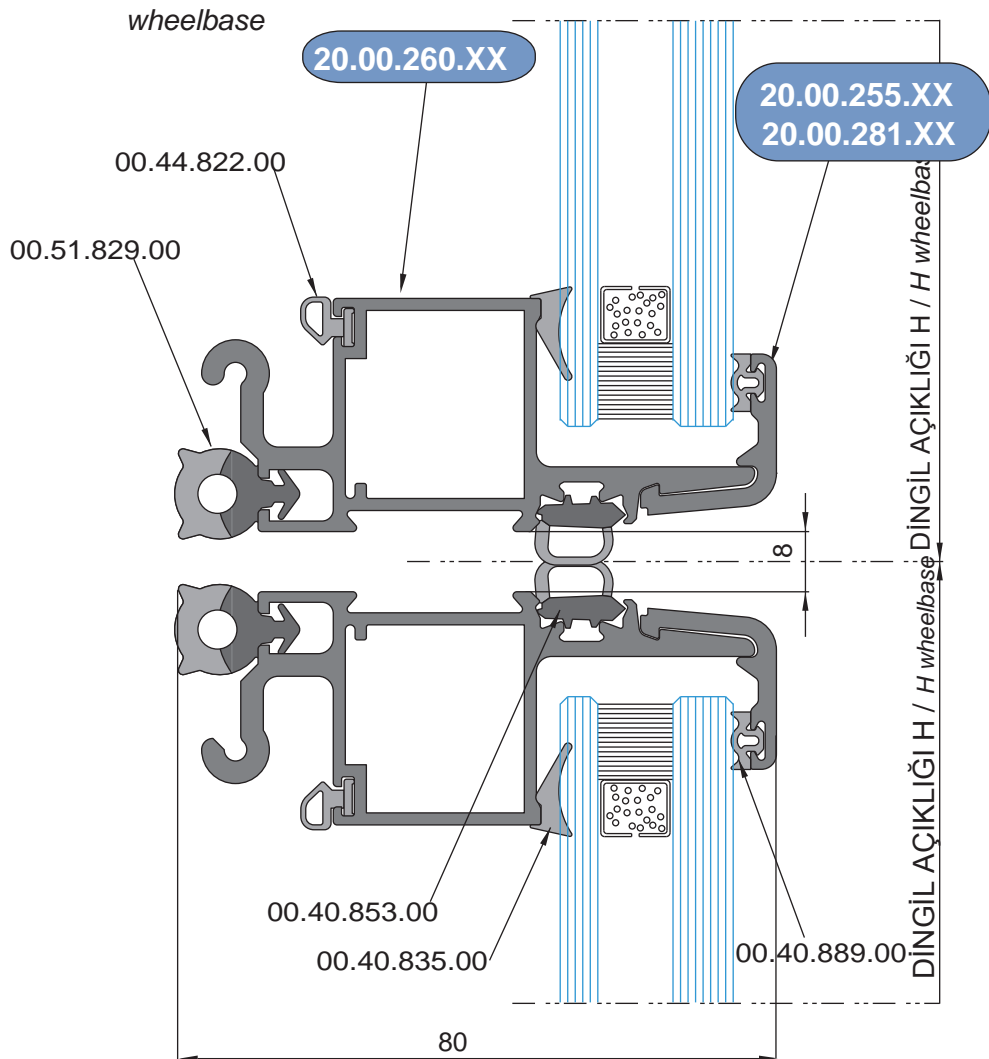
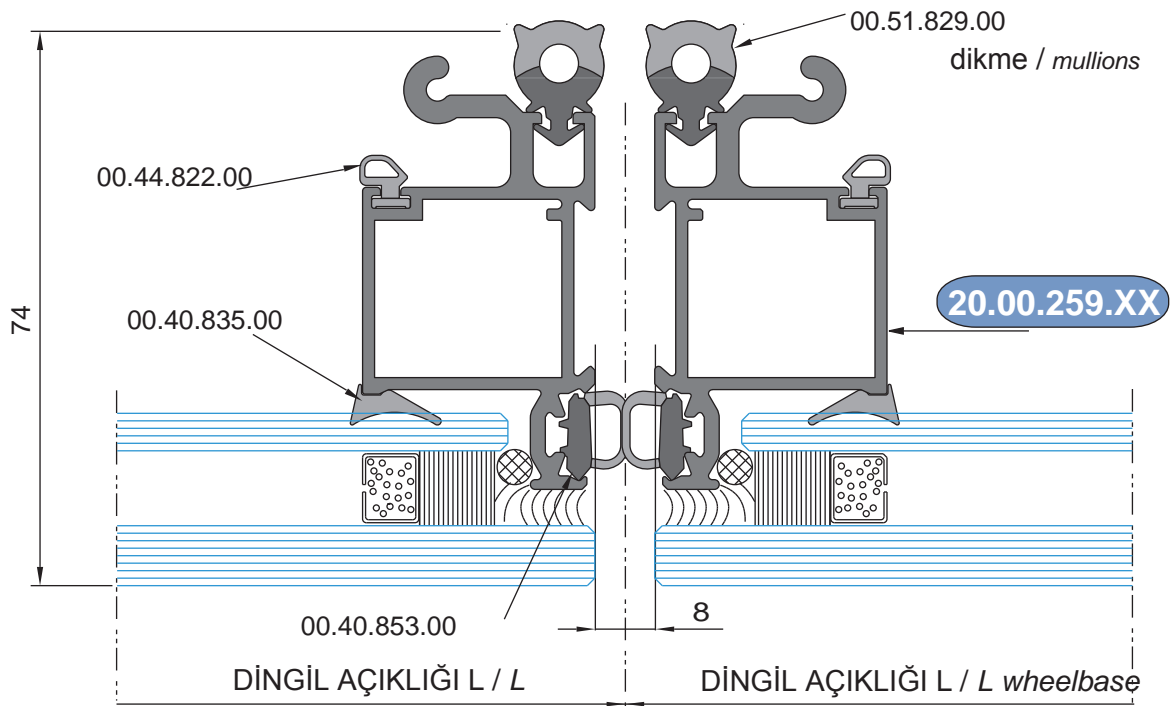

KANAT KESİTLERİ
Cutting wings table

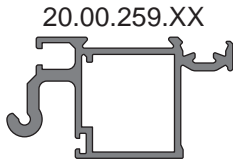
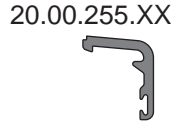
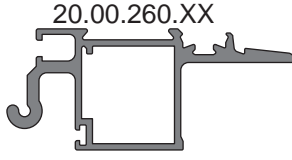

DİKEY BÖLÜM
vertical section

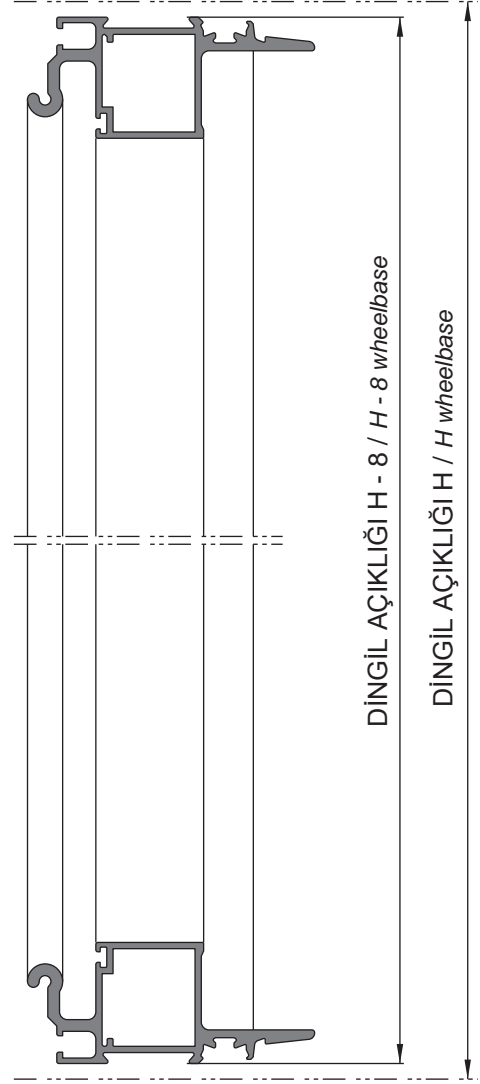

YATAY BÖLÜM
horizontal section

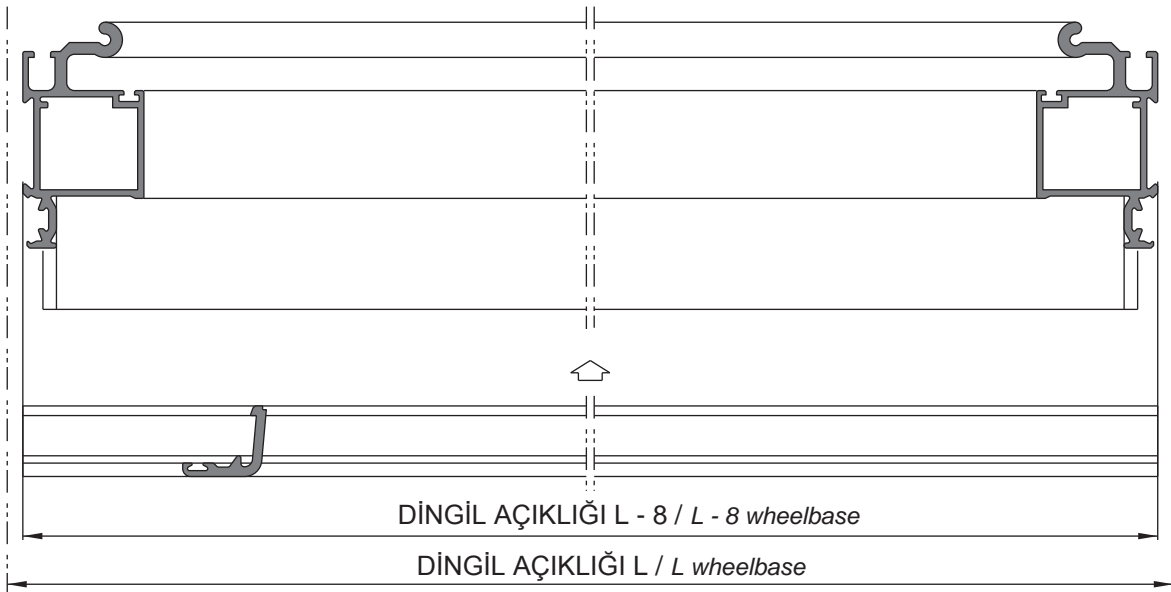

DIŞ CONTALI CAM KANAT
GLAZING WING WITH EXTRENAL GASKETS



DİKEY BÖLÜM 20.00.236.XX
horizontal section

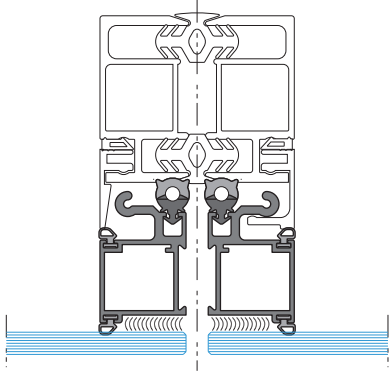

YATAY BÖLÜM 20.00.235.XX

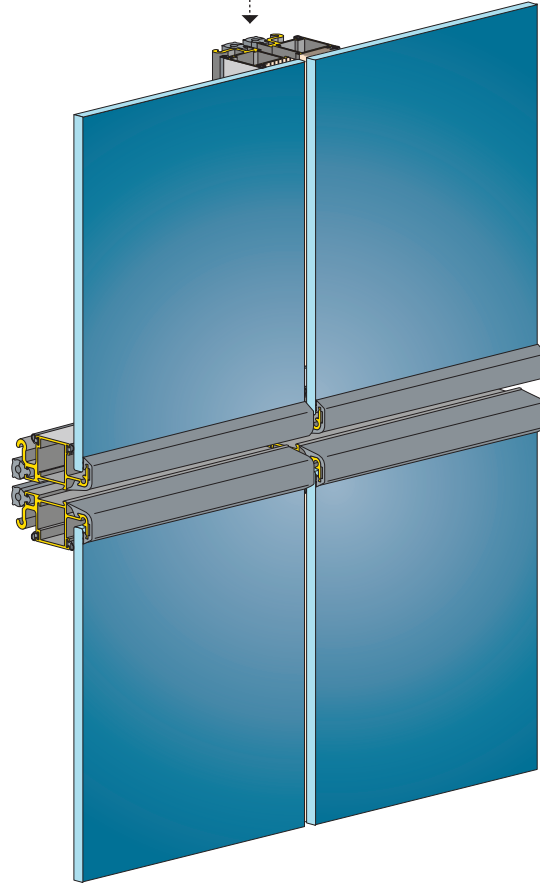
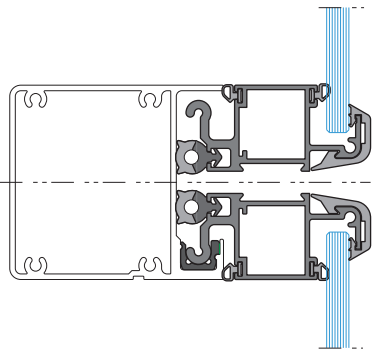

YATAY BÖLÜM
horizontal section

Kanat Cam
Glazing wing
Çift Kalın Cam 8mm
Double glazing (8mm thickness)
ağırlık/weight 1.754 Kg/ml

DİKEY BÖLÜM
vertical section

Kanat Cam
Glazing wing
Çift Kalın Cam 8mm
Double glazing (8mm thickness)
ağırlık/weight 2.118 Kg/ml

CONTA
gaskets

00.40.863.00



00.44.822.00

00.51.829.00



YATAY BÖLÜM
Horizontal section

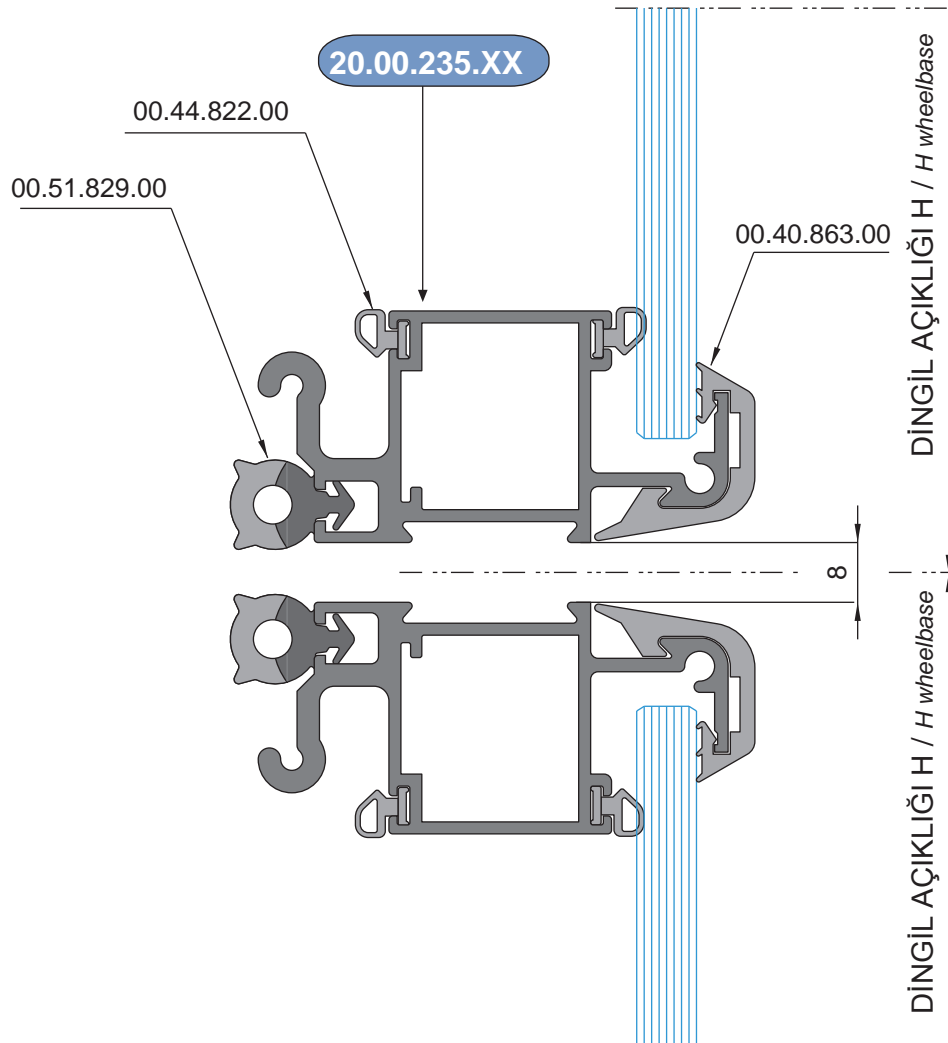
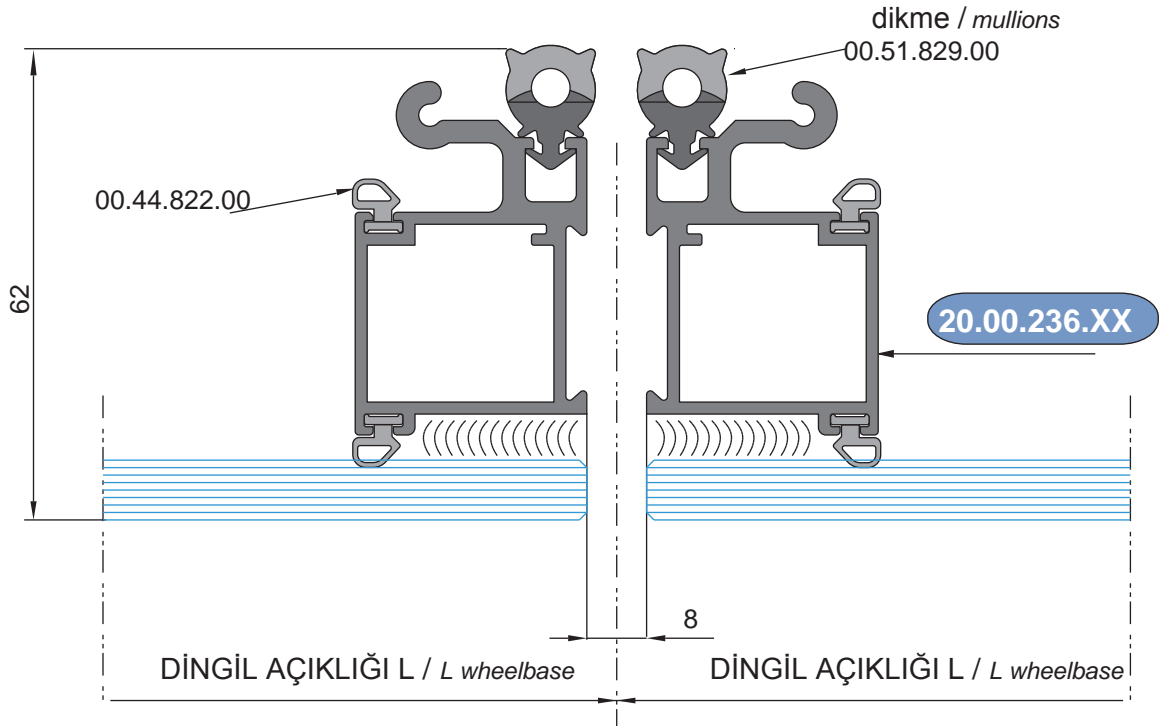

KANAT KESİTLERİ
Cutting wings table

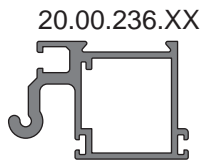
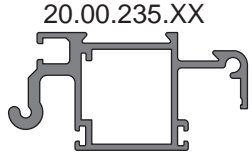

DİKEY BÖLÜM
vertical section

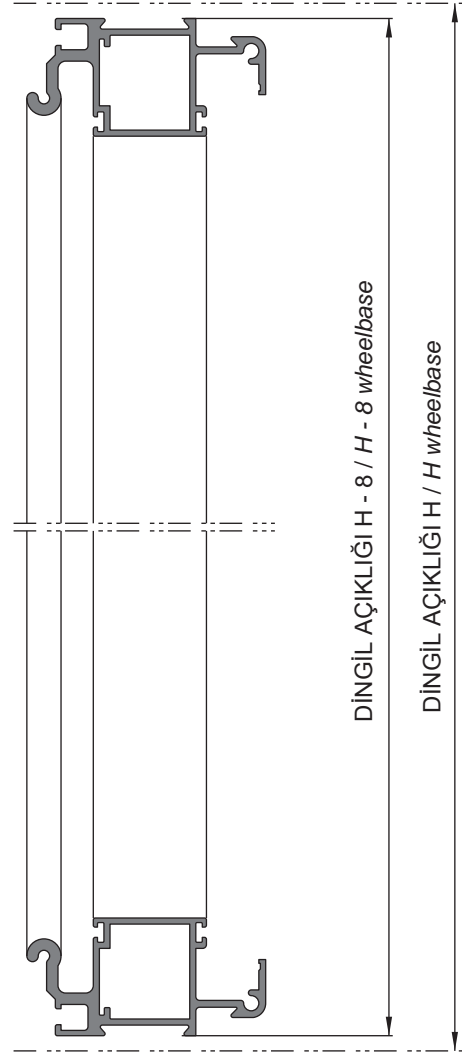

YATAY BÖLÜM
horizontal section



TABELLA GÖZLÜ CONTA
Glasses and gaskets table



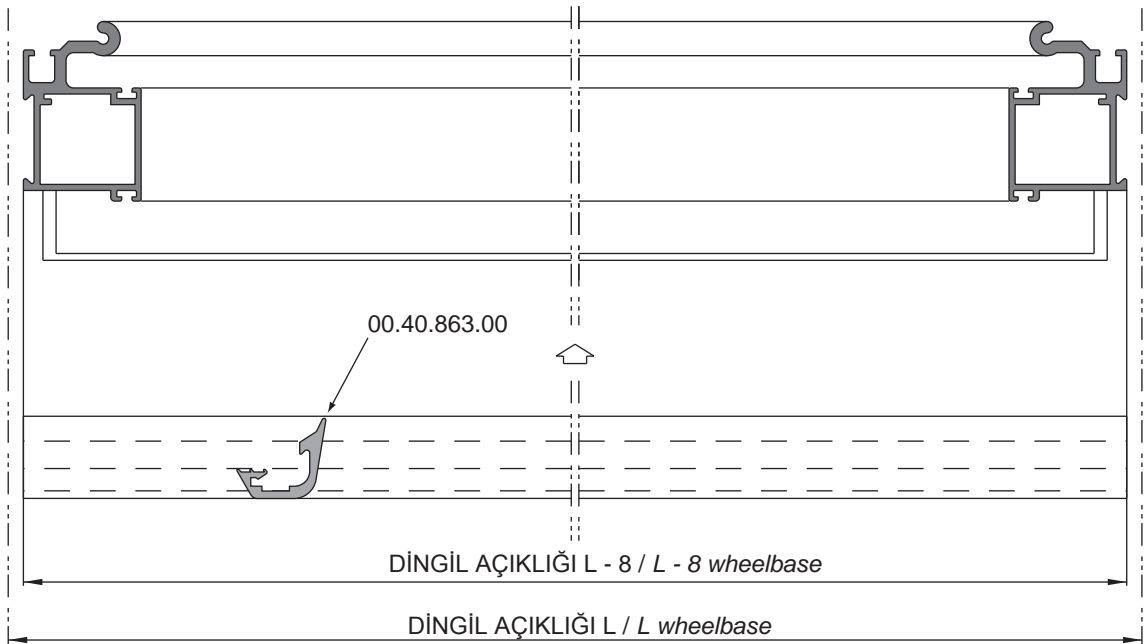
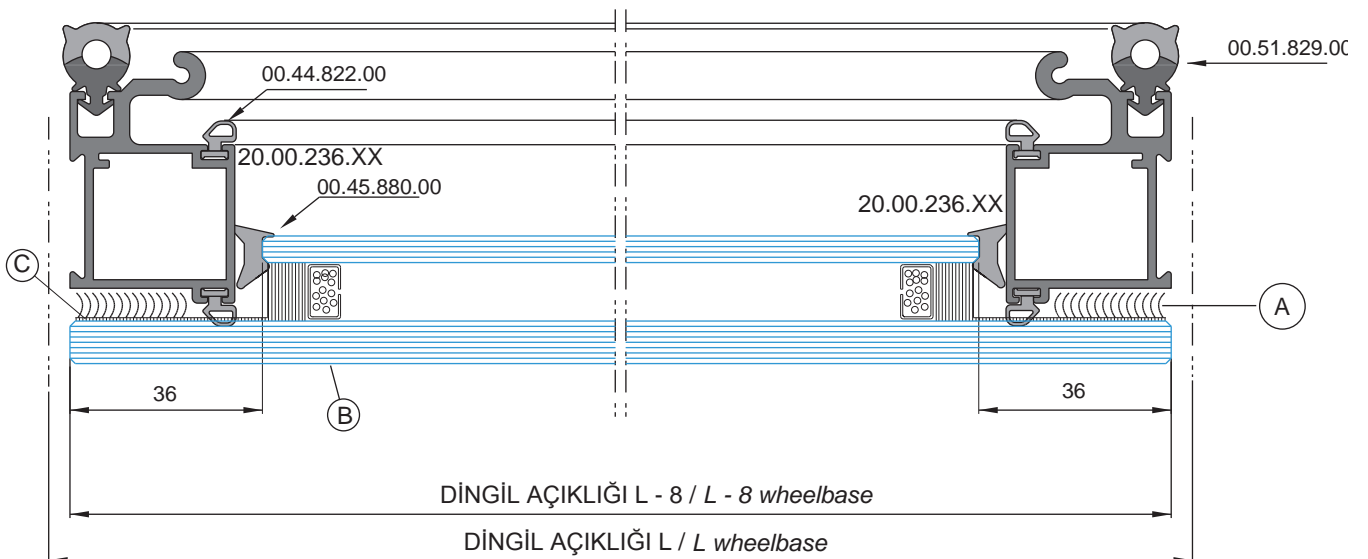
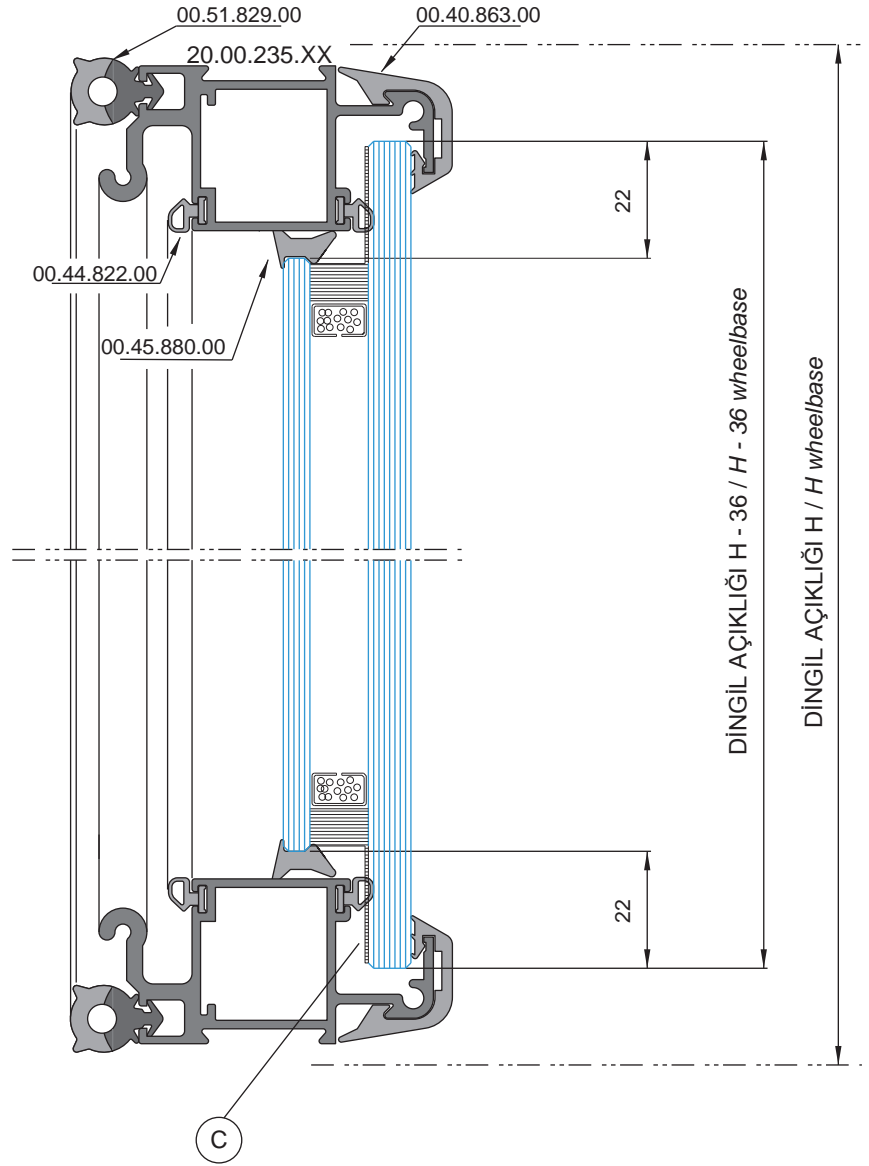
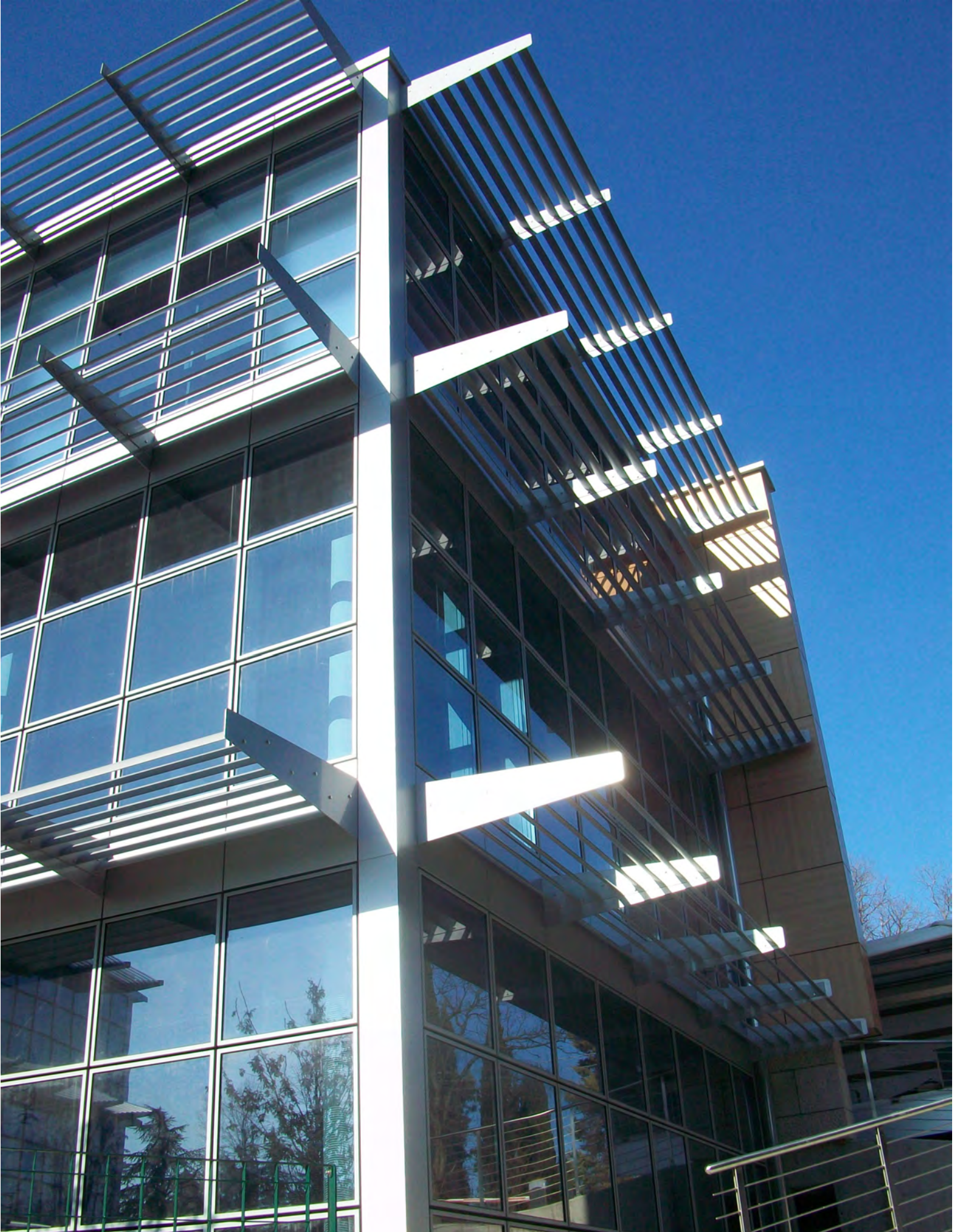

Cephe Sistemleri

Types of Facade



AÇILIR KANAT Opening wing

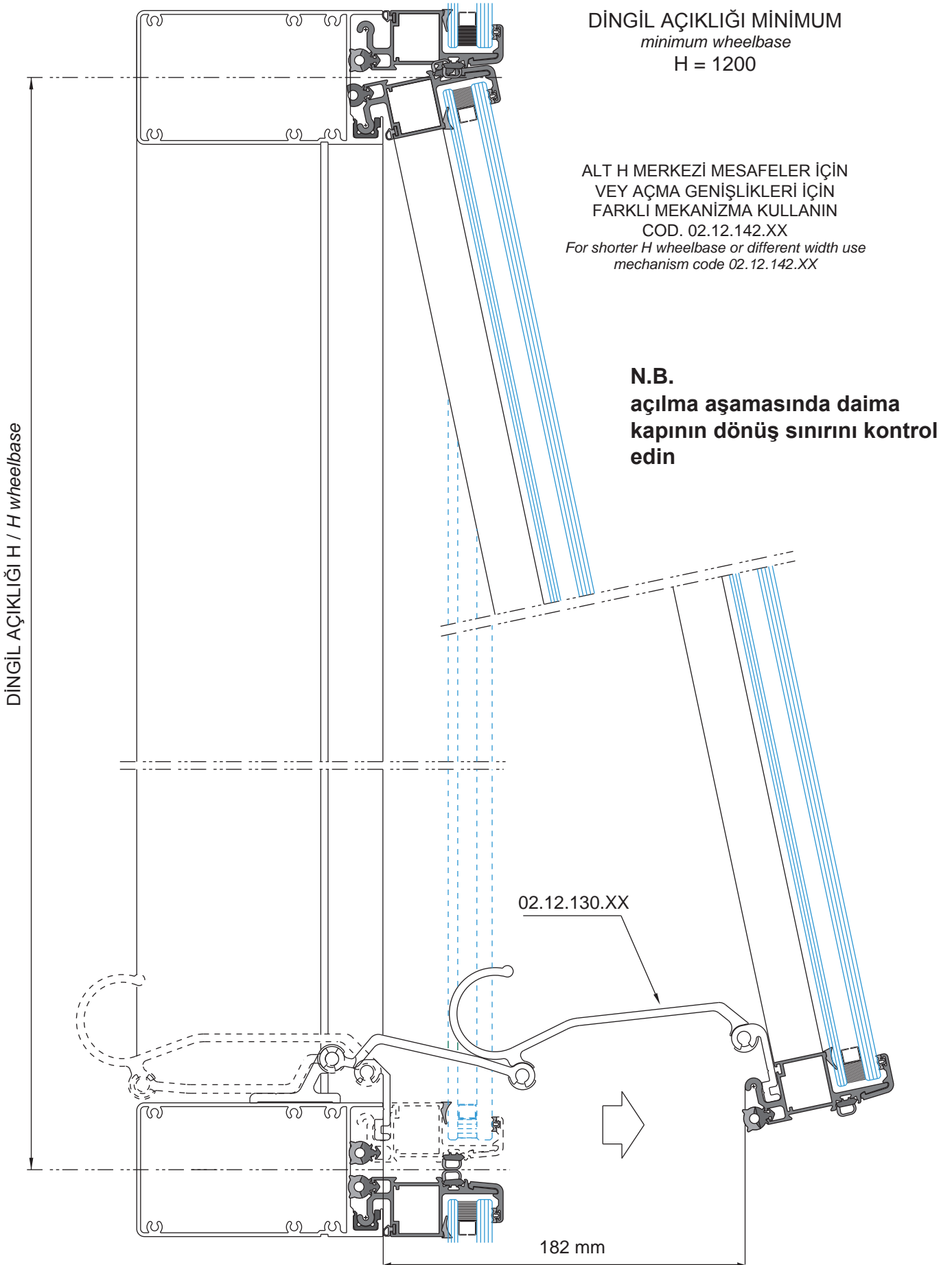

TUTMA KOLU
Handle tooling

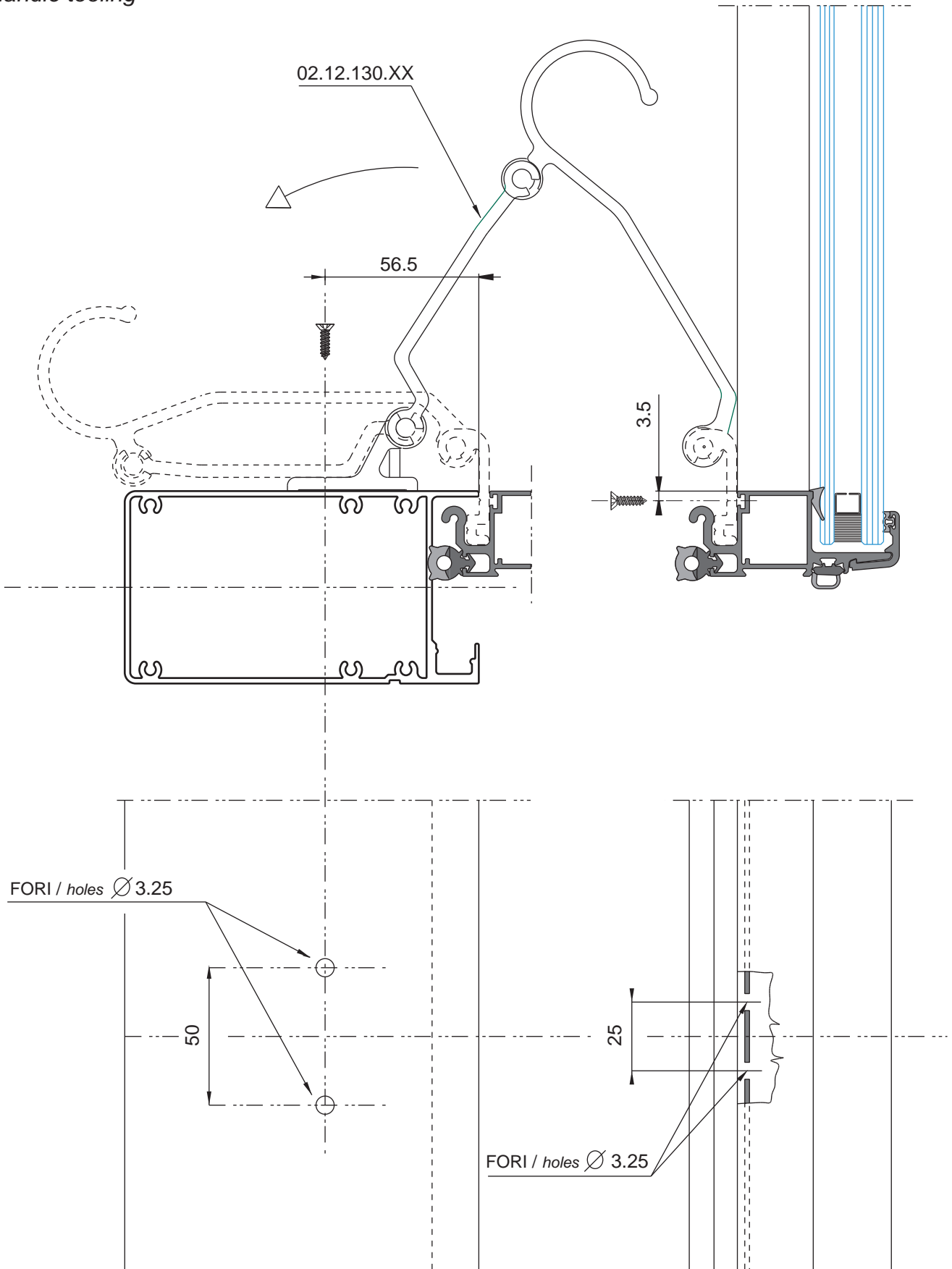

Sapın delinmesi ve montajdan sonra da yapılabilir.
It's possible drill and gather cremone bolt after placing wing.

Dış dikey kanat stoperi 02.16.145.24
External vertical wing stop 02.16.145.24

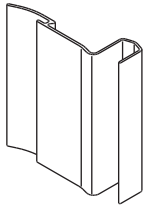

02.16.145.24

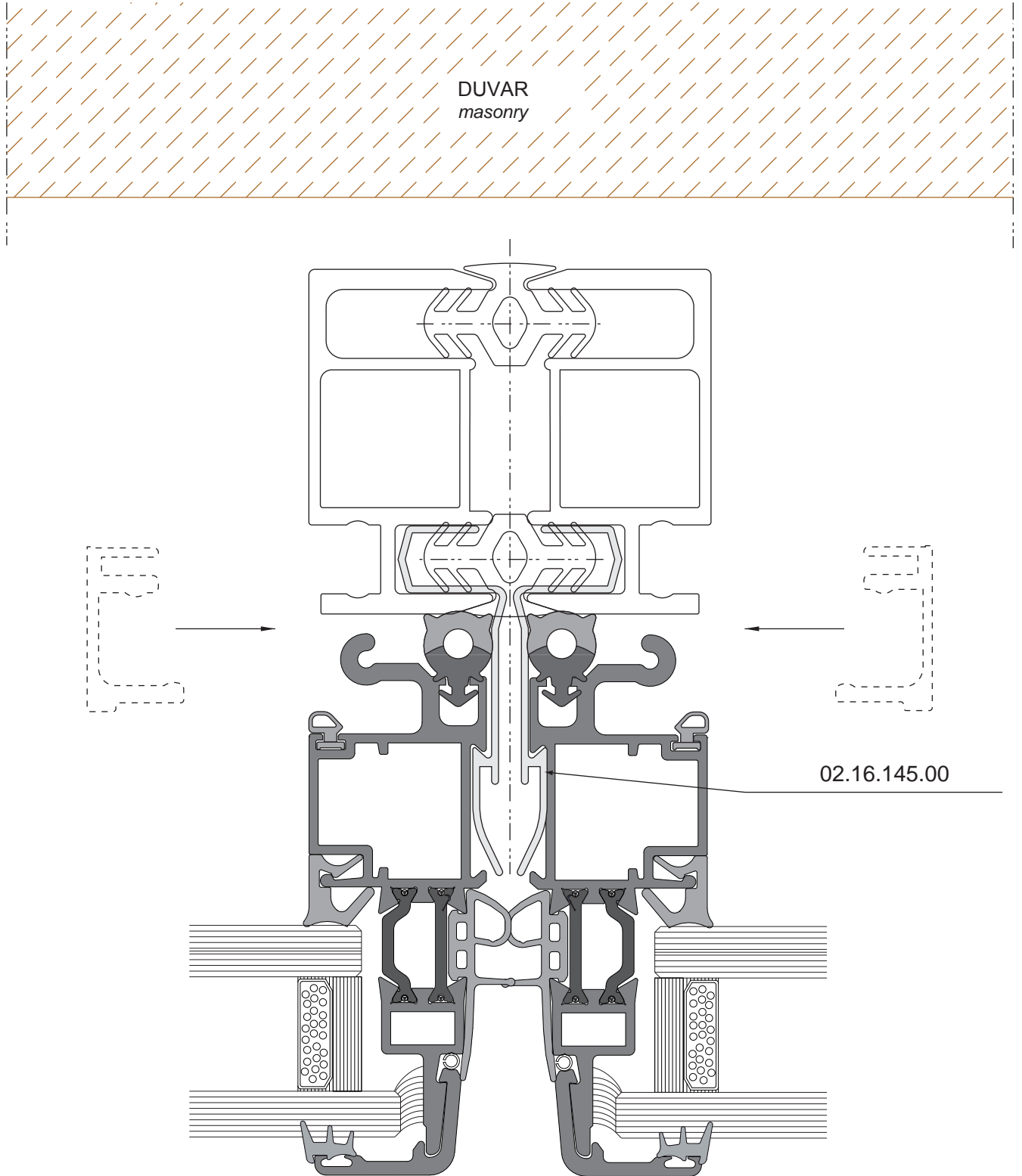

Sertifikalar Certificates



ALUMTURK

Factory: İvedik OSB Mah. 2239. Cad. No:4, 06378 Yenimahalle/Ankara
Branch: Önder Mah. Ereğli Cad. No:71/A Aldındağ/ANKARA
Branch: Yıldızevler Mh. Cezayir Caddesi no. 4/1 Çankaya/ANKARA
Branch: Fatih Mah. 30001 Sok. No:5/4 Mezitli MERSİN
<http://www.alumturk.com> e-mail info@alumturk.com
Tel. +90 312 395 1669